

AMENDMENT OF SOLICITATION/MODIFICATION OF CONTRACT			1 Contract Number	Page of Pages	
				1	82
2. Amendment/Modification Number	3. Effective Date	4. Requisition/Purchase Request No.		SEAS Laboratory Renovation Project. Building 32/42	
GF-2014-B-0194-005	February 3, 2014				
6. Issued By: University of the District of Columbia Capital Procurement Division 4200 Connecticut Avenue, NW Building 38, Room C04 Washington DC 20008		Code	7. Administered By (If other than line 6) University of the District of Columbia Capital Procurement Division 4200 Connecticut Avenue, NW Building 38, Room C03 Washington, DC 20008		
8. Name and Address of Contractor (No Street, city, country, state and ZIP Code)			(X)	9A. Amendment of Solicitation No. GF-2014-B-0194-005	
				9B Dated (See Item 11) January 15, 2014	
				10A Modification of Contract/Order No.	
				10B Dated (See Item 13)	
Code	Facility				
<b>11. THIS ITEM ONLY APPLIES TO AMENDMENTS OF SOLICITATIONS</b>					
<input type="checkbox"/> The above numbered solicitation is amended as set forth in Item 14. The hour and date specified for receipt of <input type="checkbox"/> is extended. <input checked="" type="checkbox"/> is not extended. Offers must acknowledge receipt of this amendment prior to the hour and date specified in the solicitation or as amended, by one of the following methods: (a) By completing Items 8 and 15, and returning <input type="checkbox"/> copy of the amendment; (b) By acknowledging receipt of this amendment on each copy of the offer submitted; or (c) By separate letter or fax which includes a reference to the solicitation and amendment number. FAILURE OF YOUR ACKNOWLEDGEMENT TO BE RECEIVED AT THE PLACE DESIGNATED FOR THE RECEIPT OF OFFERS PRIOR TO THE HOUR AND DATE SPECIFIED MAY RESULT IN REJECTION OF YOUR OFFER. If by virtue of this amendment you desire to change an offer already submitted, such change may be made by letter or fax, provided each letter or telegram makes reference to the solicitation and this amendment, and is received prior to the opening hour and date specified.					
12. Accounting and Appropriation Data (If Required)					
<b>13. THIS ITEM APPLIES ONLY TO MODIFICATIONS OF CONTRACTS/ORDERS, IT MODIFIES THE CONTRACT/ORDER NO AS DESCRIBED IN ITEM 14</b>					
A. This change order is issued pursuant to: (Specify Authority)					
The changes set forth in Item 14 are made in the contract/order no. in item 10A.					
B. The above numbered contract/order is modified to reflect the administrative changes (such as changes in paying office, appropriation date, etc ) set forth in Item 14, pursuant to the authority of 27 DCMR, Chapter 36, Section 3601.2					
C. This supplemental agreement is entered into pursuant to authority of:					
D. Other (Specify type of modification and authority)					
E. IMPORTANT: Contractor <input type="checkbox"/> is not <input checked="" type="checkbox"/> is required to sign this document and return 1 copy to the Issuing office					
14. Description of amendment/modification (Organized by UCF Section headings, including solicitation/contract subject matter where feasible.)					
Solicitation No. GF-2014-B-0194 for the SEAS Laboratory Renovation Project, Building 32/42 is hereby amended as follows:					
1) Questions and Answers (Attachement A)					
2) All other Terms and Conditions remain unchanged.					
Except as provided herein, all terms and conditions of the document referenced in Item (9A or 10A) remain unchanged and in full force and effect					
15A. Name and Title of Signer (Type or print)			16A. Name of Contracting Officer SHERRY JONES-QUASHIE		
15B. Name of Contractor		15C. Date Signed	16B. District of Columbia <i>Sherry Jones-Quashie</i>		16C. Date Signed 2/3/14
(Signature of person authorized to sign)			(Signature of Contracting Officer)		

# **ATTACHMENT A**

ANSWERS TO OFFERORS QUESTIONS

Questions:	Answers:
1 Spec section 064000 'Architectural Woodwork' is listed in the 'Table of Contents' but there is no actual content in the spec book; Drawing A-600, A-112 show millwork details. Please clarify.	Attached is Section 06 40 00 Architectural Woodwork. Contractor to provide all casework, equipment and furnishings as required by the Bid Documents.
2 Please confirm that Addendum 1 Drawings A-302, 304, 308 and 318 replace the entire "Window and Storefront Package Drawings" that was issued with the original drawings.	This is to confirm, Addendum 1 Drawings: A-302, 304, 308, 318 & W-501 provide the scope of exterior window work in the Contract. The "Storefront & Window Replacement Package" is not part of the original bid set and its hard copy was distributed in error.
3 Hardware Group #01 in the specs references Door #C07G, but that is not on the door schedule (sheet A-500). Is door #C07G missing on the door schedule?	The Door #C07G is been replaced by Door #C07.
4 Door #C07 on the door schedule (sheet A-500) is not referenced in the hardware schedule (in the specs). Please confirm hardware set required for this door.	The Door Hardware group is No. 01.
5 If armor plates are provided as specified (48" high x 1 1/2" less door width), they will interfere with the locksets. How should this conflict be resolved? Provide shorter armor plates or provide notch around the lock area?	Yes. Reduce Armor Plate to 36".
6 Hardware spec page 087110-2 states "provide either the named product or a comparable product by one of the manufacturers specified for each type of hardware item. Substitutions must be approved by the Architect."  <b>PART 2 PRODUCTS</b> <b>2.01 MANUFACTURERS</b>  A. Product: Subject to compliance with requirements, provide the product named for each door hardware item indicated in Door Hardware Sets.  B. Basis-of-Design Product: Product named for each door hardware item indicated in Door Hardware Sets establishes the basis of design. Provide either the named product or a comparable product by one of the manufacturers specified for each type of hardware item. Substitutions must be approved by Architect	These specifications are basis-of-design; Contractor may provide alternate hardware as a submittal subject by the Architect and Owner.

ANSWERS TO OFFERORS QUESTIONS

<p>Question # 6 continued:</p> <p>There are no alternate hardware manufacturers listed.</p> <p>Shown: Ives 5BBIHW heavyweight hinges</p> <p>Alternate: McKinney T4A3386 heavyweight hinges</p> <p>Shown: LCN 4000 series surface mounted closer</p> <p>Alternate: Corbin Russwin DCC8000 series closer</p> <p>Shown: Schlage L9000 series mortise locks, 17A lever design</p> <p>Alternate: Corbin Russwin ML2000 series mortise locks, PSA lever design</p> <p>Shown: Von Duprin 98 Series exit device</p> <p>Alternate: Corbin Russwin ED5200 series</p>	
<p>7</p> <p>Hardware spec states:</p> <p>2.10 KEYS</p> <p>A. Cylinders: Tumbler type, constructed from brass or bronze, stainless steel, or nickel silver.</p> <p>B. Equip all locking devices with BEST ACCESS SYSTEMS cylinders with removable 7-pin tumbler cores. Following approval by the University Lock Shop and the Using Agency of the final keying schedule, BEST ACCESS SYSTEMS will terminate permanent cores; cut, and tag keys, and deliver cores and keys directly to The University Lock Shop for installation by The University Lock Shop.</p> <p>1. Core/cylinder shall:</p> <p>a. be responsible for providing all permanent interchangeable lock cores and keys for the project</p> <p>b. be required to contact with the University Lock Shop for the installation of the permanent cores</p> <p>c. contact the University Lock Shop, 614-293-7693, which will develop the keys and cores into the building key system</p> <p>However, hardware sets call for Sargent cylinders. We have never seen Best SFIC at UDC - all previous work has been Sargent fixed core cylinders. Please confirm if BEST ACCESS SYSTEMS is actually required for this project.</p>	<p>BEST ACCESS SYSTEMS is not required for this project. UDC standard is Sargent, Master Key LA. The code cut will be provided to the Bidder upon Award.</p>
<p>8</p> <p>What veneer are the wood doors to be? No spec is given in section 081400.</p>	<p>It is to match existing wood veneer.</p>

ANSWERS TO OFFERORS QUESTIONS

9	Are hollow metal frames to be welded or knockdown? Specs on page 08113-3 indicate that rated frames are welded and non-rated frames are knockdown. Is that correct?	The hollow metal frames are to be all welded.
10	Please confirm that only frame elevation type ONE is used on this project.	Confirmed, Type One is the only frame in this project.
11	Why are there no additional door/frame/hardware details for door #'s 111E and 111F on the door schedule? Are these openings existing to remain?	Door #111F is a new door entering the Modeling & Simulation Lab (C01A). Door #111E has been removed from the project.
12	Door #A09C does not have any door or frame details on the door schedule, but does reference hardware set 13. Is this supposed to be new hardware for an existing door?	Door # A09C is similar to Door # A09A.
13	Drawing G012-G014, the notes on the Specialty Equipment Calibration and Repair Schedule are not legible. Please provide readable notes for that schedule.	Refer to Specification Section 01 21 00 (3.3) (A) (1) for the Specialty Equipment Calibration and Repair Schedule.
14	Please provide the missing asbestos report.	The Asbestos Report is not missing, but a deliverable provided by the AE for the benefit of the Owner. Refer to the Bid Documents for all work related to Hazardous Waste Testing, Verification, Abatement and Disposal associated with this Project. The Report was used to generate these requirements. A hard copy of the report may be reviewed at the Capital Construction Office during normal business hours of 9:00 am and 4:00 pm.
15	Please provide the following specification sections for the following: a. Signage b. Entrance grate c. Door operators d. Concrete per drawing W501	<ul style="list-style-type: none"> <li>a) Attached is Section 10 14 10 Interior Signage.</li> <li>b) Attached is Section 12 48 23 Entrance Floor Grids</li> <li>c) Attached is Section 08 71 13 Automatic Door Operators.</li> <li>d) Attached is Revised Section 03 30 00 Cast-in-Place Concrete.</li> </ul>
16	Do the new building controls and fire alarms need to be connected with the existing systems? If so, please provide the manufacturer's names of the existing systems.	Yes. Existing Fire Alarm System by Simplex Grinnell. Campus Energy Management System by Johnson Controls.

ANSWERS TO OFFERORS QUESTIONS

17	Drawing P103 shows new sanitary lines. Do the existing concrete slabs need to be saw-cut and patched?	Yes, refer to Demolition General Note No. 17 on AD-Series Drawings.
18	Will there be another site visit for the subcontractors to inspect the existing conditions?	All site visits must be authorized by the Capital Procurement Division Office. The site is available for inspection during normal business hours of 9:00 am and 4:00 pm. The Bidder or potential sub-contractor is required to bring their own survey equipment and coordinate access with the Capital Construction Division.
19	Page 96 of the solicitation indicates the bid submission is 2/12/14, where addendum #3 shows as 2/6/14. The bid date 2/6/14 and/or 2/12/14 will not give ample time for the subcontractors to visit and inspect the site, provide RFIs, and get competitive pricing from their vendors to submit a responsible bid. Therefore, we request the RFI deadline and bid date be extent.	The response date for bid submission has been extended to Thursday, February 13, 2014, 2:00 PM. Please refer to amendment no. 004.
20	Also, is the storefront and window package part of this bid?	Refer to Response to Bidder Question No. 2.
21	<p>Are these notes applicable to this project:</p> <p><b>E.3 FINAL INSPECTION:</b></p> <p>E.3.1 The Contractor shall give the CA written notice at least fourteen (14) days in advance of date on which the project will be 100% complete and ready for final inspection. Prior to final inspection date, the Contractor shall verify in writing that in the Contractor's best judgement no deficiencies exist. The Contractor shall conduct two inspections. An inspection shall be conducted after the installation of structural steel and security glass. And an inspection shall be conducted after the dismantling of the stands.</p>	<p>For an overview of requirements related to the inspection process at Contract Closeout, refer to Specification Section 01 77 00 Closeout-Procedure. Omit <i>"The Contractor shall conduct two inspections. An inspection shall be conducted after the installation of structural steel and security glass. And an inspection shall be conducted after the dismantling of the stands."</i> The Contractor is required to inspect the quality of their work and the work of their sub-contractors for conformance with the Contract. Inspections and testing shall be conducted according to the requirements of the Contract.</p>
22	<p>Which is the correct time of completion:</p> <p><b>F.1 TIME OF COMPLETION:</b></p> <p>The Contractor shall commence work on the date specified in the written Notice to Proceed (NTP) signed and issued by the Contracting Officer (CO) and shall start and complete all the work within one hundred eighty (120) calendar days from the Notice to Proceed.</p>	<p>The Period of Performance is two-hundred and twenty days (220) from the Notice to Proceed. For Occupant Constraints and Construction Sequencing refer to Sheet G-012, G-013 &amp; G-014 of the Contract Drawings.</p>
23	Please provide the missing specification section 238216.14 Coils.	Attached spec section "237313 – Modular Indoor Central Station Air Handling Units." This should replace the current version of this

**ANSWERS TO OFFERORS QUESTIONS**

		<p>specification.</p> <p>Spec section 238216.14 should be removed from Division 26 and added to Division 23.</p>
<p>24</p>	<p>Please provide missing specification sections for duct insulation and equipment insulation.</p> <p>23 05 53 IDENTIFICATION FOR HVAC PIPING AND EQUIPA          23 05 93 TESTING, ADJUSTING, AND BALANCING FOR HV.          23 07 13 DUCT INSULATION          23 07 16 HVAC EQUIPMENT INSULATION</p>	<p>Attached spec section 230713 – Duct Insulation          Spec 230716 is not required.          Specifications 23 05 53 &amp; 23 05 93 are part of Construction Documents – Issued for Bid (100%) January 14, 2014, Volume 2</p>

**University of the District of Columbia**  
**School of Engineering and Applied Sciences Laboratory Renovation**

**Project Number: 13334.01**

**Addendum 2 – Revision 2**

**01.31.2014**

**NOTE: This document replaces Addendum 1 – Revision 1 Document previously issued.**

**SPECIFICATIONS SECTIONS**

1. Add Section 03 30 00 - Cast-in-Place Concrete
2. Add Section 08 71 13 - Automatic Door Operators
3. Add Section 12 48 23 - Entrance Floor Grids
4. Add Section 10 14 10 - Interior Signage
5. Add Section 13 28 00 - Hazardous Materials Remediation – General
6. Add Section 13 28 10 - Hazardous Waste Management
7. Add Section 13 28 20 - Removal and Disposal of ACM's
8. Replace Section 23 82 16.14 - Coils.
9. Remove 23 82 16.14 from Division 26 and move to Division 23
10. Add Section 23 07 13 – Duct Insulation

**ARCHITECTURAL DRAWINGS**

**G-001** Replace this sheet.

**G-006**

1. PLAN REVISION: Refer to Revised Sheet A-110 for plan revisions at the following locations: C06 Signal Closet; C07 Power Systems Lab; C08A Civil Grad Research Office

**G-012**

1. PLAN REVISION: Refer to Revised Sheet A-110 for plan revisions at the following locations: C06 Signal Closet; C07 Power Systems Lab; C08A Civil Grad Research Office

**AD-101**

1. PLAN REVISION: Revise Plan 1 Demolition Level C per Sketch AD-111a.
2. PLAN CHANGE: Signal Closet (C06) is Not in Contract per Sketch AD-111a.
3. DEMOLITION GENERAL NOTES:
  - a. Delete Demolition General Note 22
  - b. Revise Demolition General Note 4 as follows: "CONTRACTOR SHALL FIELD VERIFY THEIR WORK WITH THE DEMOLITION DRAWINGS, NEW CONSTRUCTION DRAWINGS,



SPECIFICATIONS AND EXISTING CONDITIONS. CONTRACTOR ARE RESPONSIBLE TO FIELD VERIFY THE EXTENT OF DEMOLITION WORK PRIOR TO BIDDING AND FOR COORDINATING THE EXTENT OF DEMOLITION WITH THE INSTALLATION OF NEW SYSTEMS AND FINISHES INDICATED IN THE CONTRACT DOCUMENTS. CONTRACTOR SHALL IMMEDIATELY NOTIFY THE DESIGN-BUILDER OF ANY DISCREPANCIES BEFORE COMMENCING WITH WORK.

- c. Revise Demolition General Note 5 as follows: "CONTRACTOR SHALL FIELD VERIFY ALL EXISTING FLOOR, WALL, CEILING AND ROOF CONSTRUCTION AND HEIGHTS PRIOR TO COMMENCEMENT OF THE WORK. CONTRACTOR SHALL VERIFY ALL DIMENSIONS AND CLEARANCES BEFORE COMMENCING WITH WORK. COMMENCEMENT OF THE WORK CONSTITUTES ACCEPTANCE OF THE EXISTING CONDITIONS. CONTRACTOR SHALL IMMEDIATELY NOTIFY THE OWNER'S REPRESENTATIVE OF ANY DISCREPANCIES BEFORE COMMENCING WITH WORK."
- d. Revise Demolition General Note 6 as follows: " CONTRACTOR SHALL MAINTAIN ALL LEGAL EGRESS FROM EXISTING BUILDING."
- e. Revise Demolition General Note 8 as follows: "CONTRACTOR ARE RESPONSIBLE FOR ALL OTHER ITEMS TO BE REMOVED AND SALVAGED."
- f. Revise Demolition General Note 17 as follows: "CONTRACTOR SHALL CUT AND PATCH EXISTING CAST-IN-PLACE CONCRETE FLOOR SLAB AS REQUIRED FOR ALL BELOW-FLOOR WORK. COORDINATE ALL WORK WITH APPROPRIATE AND AFFECTED TRADES. WHERE REQUIRED OR INDICATED, NEATLY AND CLEANLY SAW-CUT AND REMOVE THE CAST-IN-PLACE CONCRETE SLAB, EXCAVATE AND REMOVE SUB BASE AS REQUIRED FOR THE INSTALLATION OF BELOW-FLOOR WORK. WIDTH OF TRENCH SHALL BE AS REQUIRED TO FURNISH AND INSTALL THE WORK WITHOUT UNDERMINING THE ADJACENT CAST-IN-PLACE CONCRETE FLOOR. BACKFILL WITH GRANULAR FILL. PATCH AND REPAIR CAST-IN-PLACE CONCRETE FLOOR TO MATCH ADJACENT EXISTING FLOOR SURFACE WITH SAME FINISH MATERIAL."

### **AD-102**

Demolition General Notes No. 4, No. 5, No.6, No. 8 and No. 17 have been revised. And note No.22 have been eliminated. (Refer to AD-101 Item 3 above)

### **AD-103**

Demolition General Notes No. 4, No. 5, No.6, No. 8 and No. 17 have been revised. And note No.22 have been eliminated. (Refer to AD-101 Item 3 above)

### **AD-111**

1. DEMOLITION CODE NOTES: Refer to Sketch Number AD-111a for revised Demolition Coded Notes and associated plan revisions

#### **AD-200**

1. PLAN REVISION: Signal Closet (C06) is Not in Contract per Sketch Number AD-111a.
2. Demolition General Notes No. 4, No. 5, No.6, No. 8 and No. 17 have been revised. And note No.22 have been eliminated. (Refer to AD-101 Item 3 above)

#### **AD-201**

1. Demolition General Notes No. 4, No. 5, No.6, No. 8 and No. 17 have been revised. And note No.22 have been eliminated. (Refer to AD-101 Item 3 above)

#### **A-100**

1. PLAN REVISION: Refer to Revised Sheet A-110 for plan revisions at the following locations: C06 Signal Closet; C07 Power Systems Lab; C08A Civil Grad Research Office
2. SHEET NOTES:
  - a. Revise Sheet Note 11 as follows: "CONTRACTOR, SHALL PROVIDE AND LOCATE ACCESS DOORS / PANELS IN WALL AND CEILING CONSTRUCTION AS REQUIRED TO PROVIDE ACCESS TO MECHANICAL, FIRE SPRINKLER, PLUMBING AND ELECTRICAL WORK. CONTRACTOR SHALL SUBMIT A PLAN OF PROPOSED ACCESS PANEL LOCATIONS TO ARCHITECT FOR APPROVAL PRIOR TO INSTALLATION."

#### **A-101**

SHEET NOTES: Revise Sheet Note 11 per Sheets A-110.

#### **A-102**

SHEET NOTES: Revise Sheet Note 11 per Sheet A-110.

PLAN REVISION: Revise Plan 2 Overall Roof Plan per Sketch 102a.

**A-110** Replace the sheet.

#### **A-111**

SHEET NOTES: Revise Sheet Note 11 per Sheet A-110.

#### **A-112**

SHEET NOTES: Revise Sheet Note 11 per Sheet A-110.

#### **A-200**

PLAN CHANGE: Revise Reflected Ceiling Plan per Sketch A-211a.

**A-211**

PLAN CHANGE: Revise Reflected Ceiling Plan per Sketch A-211a.

**A-302** NEW SHEET: A-302 Storefront Demolition Plans

**A-304** NEW SHEET: A-304 Storefront New Work Plans

**A-308** NEW SHEET: A-308 Storefront Elevations

**A-318** NEW SHEET: A-318 Schedule and Details

**A-500** REPLACE Sheet A500.

**A-700**

FINISH SCHEDULE: Revise Finish Schedule per attached Sketch A-700a.

**A-701**

FINISH FLOOR PLAN: Revise Plan 1/A701 per Sketch A701a.

**A-800**

FF&E SCHEDULE: Revise FF&E Schedule per attached Sketch A-800a.

**A-802**

FURNITURE LAYOUT: Revise Furniture Layout per attached Sketch A-802a.

**A-900** Replace this Sheet.

**A-901**

PLAN REVISION: Revise Plan 1 Signage Level C – Part 1 per Sketch A901a.

**A-902**

PLAN REVISION: Revise Plan 2 Signage Level C - Part 2 per Sketch A-901b.

**Q-201**

1. PLAN REVISION: Room C07 Power Systems Lab
  - a. Identify Equipment Number 157 as “Existing”.
  - b. Identify Equipment Number 158 as “Existing”
  - c. Identify Equipment Number 160 as “Existing”.
  - d. Identify Equipment Number 161 as “Existing”
  - e. Identify Equipment Number 162 as “Existing”.

**Q-601**

1. GENERAL NOTES: Added a General Note 1: 1. REFER TO MECHANICAL SCHEDULES AND DETAILS FOR EXHAUST FAN SCHEDULE AND FUME HOOD CONNECTION DETAIL
2. Add Fume Hood Schedule per Sketch Q-601a.

**W501** NEW SHEET: W-501 Waterproofing Details

## **MECHANICAL DRAWINGS**

### **M-102**

PLAN REVISION: Add FCU condensing units for demolition

ADD SHEET NOTE 7: "Remove existing condensing units and associated evaporator unit, piping, electrical, and controls. Mounting rack to remain and be used for new installation."

### **M-103**

PLAN REVISION: Remove details for Mechanical Room C04D. See drawing M201 for mechanical room detail.

REVISE SHEET NOTE 3: "New mechanical room. See part plan for equipment in this room."

REVISE SHEET NOTE 9: "AHU-1 Control Panel."

### **M-104**

PLAN REVISION: Revise ductwork, diffusers, returns, etc. as shown per architectural layout change.

ADD SHEET NOTE 13: "Connect to existing exhaust for storage closet."

### **M-108**

PLAN REVISION: Move roof equipment West to match mechanical shaft location.

### **M-201**

PART PLAN REVISION: Add valves and damper actuators to mechanical room part plans as shown and per directions on drawing MC501

PART PLAN ADDITION: Add detail for Mechanical Room C04D.

### **M-403**

DETAILS: Add fume hood and condensate pump details.

### **M-501**

- VENTILATION RATE SCHEDULE: Update per new architectural layout
- CONDENSATE PUMP SCHEDULE: Add to drawing
- AIR HANDLING UNIT SCHEDULE: Change AHU-1 steam heating coil data as shown.

## **PLUMBING DRAWINGS**

### **P-104**

- PLAN REVISION: Add temporary location for compressor serving equipment in C12
- PLAN REVISION: Add air dryer for laboratory compressed air in C Level Mechanical Room
- ADD SHEET NOTE 20: "Temporary relocation point of remote air compressor serving spectrometer lab #C12. Provide all temporary power, piping, conduit, etc. required to maintain operation throughout the construction process. Coordinate and associated service outages with the owner and other disciplines performing work in this lab area."

### **P-106**

- PLAN REVISION: Add NG drop symbol in cleanroom utilities closet to make shut-off valves accessible.
- PLAN REVISION: Add callout note to rack pipes on wall
- PLAN REVISION: Add callout note to provide "unistrut or trapeze pipe holder."

## **ELECTRICAL DRAWINGS**

### **E-102**

- PLAN REVISION: Change light fixtures and light switch to equipment to remain in room C06
- ADD SHEET NOTE 6: "Light fixtures and light switched ot remain in this room. Disconnect lighting circuit serving this room and retain for reconnection. See Dwg E-104."

### **E-104**

- PLAN REVISION: Change light fixtures and switch in storage room to existing to remain.
- PLAN REVISION: Revise light fixture layout in rooms C07 & C08A per new architectural layout.
- ADD SHEET NOTE 7: "Existing light fixtures in this room to be connected to new lighting circuit 2HC1-1 as shown."

### **E-106**

- PLAN REVISION: Change receptacles and junction box to equipment to remain in room C06.
- ADD SHEET NOTE 4: "Outlets and receptacles to remain in this room. Disconnect associated branch circuit and salvage for reconnection. See Drawing E108."

### **E-107**

- PLAN REVISION: Add new electrical connection for condensate pump and mechanical control panel in new mechanical room C04D. NOTE: This revision is shown on sketch E108A

### **E-108**

- PLAN REVISION: Change receptacles and junction box to existing to remain in room C06 (E108A).

- PLAN REVISION: Change power distribution of electrical equipment in Power Lab room C07 and in room C08A (E108A).
- REVISE SHEET NOTE 9: "Not used." (E108A)
- ADD SHEET NOTE 18: "Existing power outlets in this room to be reconnected to new spare circuit breaker in panel 2LC-PL" (E108A)
- PLAN REVISION: Add branch circuit number to neutralizer sump pump (E108B)
- PLAN REVISION: Delete disconnect switch and add single receptacle for neutralizer sump pump connection. (E108B)
- PLAN REVISION: Delete duplication of surface mounted raceway in lab C10B. (E108B)
- PLAN REVISION: Add automatic door operator to the 2<sup>nd</sup> entrance door at Entry Vestibule C03. (E108B)

#### **E-112**

- PLAN REVISION: Delete receptacle NEMA 6-30R in room 111B. (E112A)
- PLAN REVISION: Add junction box at utility closet 111C for new power to Modular Clean Room. (E112A)
- ADD SHEET NOTE 20: "Junction box for modular clean room power supply." (E112A)
- ADD SHEET NOTE 19: "Run new home runs of new fans to panel 2H2 via existing roof penetration. Contractor to verify." (E112B)
- PLAN REVISION: Replace panel 2L2-P with new panel 2L2-P (E112C)
- ADD SHEET NOTE 21: "Replace panel 2L2-P with new panel 2L2-P 150A, 208/120V, 3ph., 4 wire. Provide per panel schedule." (E112C)
- PLAN REVISION: Replace motor starter and AHU-2C fan motor with new controller VFD type and new fan motor. (E112D)
- ADD SHEET NOTE 22: "Replace motor starter with new controller VFD type for new 15HP fan motor. Reconnect new VFD to existing branch feeder. Provide final connection from VFD to new AHU fan motor with 3#8+1#10AWG in ¾" LFMC." (E112D)
- ADD SHEET NOTE 23: "Identify and connect to one spare circuit in 120/208V panel in adjacent electrical room with 2#12+1#12 (G) in ¾" conduit. Provide one new 20A/1 circuit breaker." (E112D)

#### **E-301**

- RISER REVISION: Extend demolition of conduit serving panel 2LC-AS back to disconnect switch source.
- RISER REVISION: Demolish panel 2L2P in 2<sup>nd</sup> floor electrical room.

#### **E-302**

- RISER REVISION: Add new feeder to panel 2LC-AST extended to power source disconnect.
- RISER REVISION: Change capacity of panel 2L1REM from 100A to 225A.
- RISER REVISION: Change feeder to panel 2L1REM from #1AWG to 2/0AWG.

- RISER REVISION: Add new panel 2L2P 150A to replace the existing one.
- ADD SHEET NOTE 18: "Panel 2L2P 225A, 208/120V, 3ph., 4 wire."

#### **E-501**

- LAB EQUIPMENT SCHEDULE: Change junction box and power characteristic to Modular Clean room to 40A 3-phase, 4-wire.

#### **E-502**

- EQUIPMENT DISCONNECT AND CONTROL SCHEDULE: Change enclosure type for AHU-1 to NEMA 1.
- EQUIPMENT DISCONNECT AND CONTROL SCHEDULE: Change controller type of HV-1 from VFD to full voltage motor starter and change enclosure to NEMA 1.
- EQUIPMENT DISCONNECT AND CONTROL SCHEDULE: Change controller type of EF-1 from full voltage motor starter to VDF.
- EQUIPMENT DISCONNECT AND CONTROL SCHEDULE: Add VFD controller for existing AHU-2C

#### **E-504**

- ADD PANEL SCHEDULE: Add panel schedule of existing panel 2LA-2 (E504A)
- ADD SHEET NOTE 1: "Replace circuit breakers 20A, 120V, 1 pole with new circuit breaker 60A, 208V, 3 pole. Existing circuit breakers will be available after demolition of receptacles in Level A classroom. See drawing E-111." (E504A)
- ADD PANEL SCHEDULE: Add panel schedule on new panel 2LP-2 (E504B)
- ADD SHEET NOTE 2: "Existing main feeder and branch circuits to be reconnected to new panel 2L2-P. Extend existing main feeder and branch circuits as required. Trace and identify existing branch circuits and provide new updated card directory. Coordinate with owner for circuit tracing." (E504B)

#### **E-505**

- PANEL 2L1-REM: Change branch feeder to Modular Clean room from 30A, 2-pole to 40A, 3-pole.

### **Fire Alarm Drawings**

#### **FA-104**

- PLAN REVISION: Change layout to accommodate new Level C layout

### **FIRE PROTECTION DRAWINGS**

#### **FP-101**

- **PLAN REVISION:** Change sprinkler layout per new Level C layout

**FP-102**

- **PLAN REVISION:** Change sprinkler head type in room C12.

**HAZARDOUS MATERIALS DRAWINGS**

**H-101** NEW SHEET: H-101 Hazardous Materials

**H-102** NEW SHEET: H-101 Hazardous Materials

**H-103** NEW SHEET: H-101 Hazardous Materials

- **NOTE:** The above descriptions are used as a guide to supplement to the drawings.



**SECTION 03 30 00****CAST-IN-PLACE CONCRETE****PART 1 GENERAL**

## 1.01 WORK INCLUDED

- A. Basic Specification: Perform work of this Section according to ACI 301, "Specifications for Structural Concrete for Buildings," except as specifically modified herein. Numbers in parentheses (0.00) indicate a related paragraph of ACI 301.
- B. Work Included: All cast-in-place concrete work shown on the Drawings and required by these Specifications. Allow for the installation of cast-in items furnished under other Sections. Install anchor bolts for structural steel. Provide and install grout under steel column base plates and beam bearing areas.
- C. Cooperate with other trades who will provide and install items of work (sleeves, piping, conduit, inserts, etc.) to be cast in the concrete. Place no concrete until all such items are in place.
- D. Inspection and testing services required by this Section are to be performed by an agency retained by the Contractor (1.6.3) subject to the Architect's approval. This includes not only the services required to establish mix designs, but also includes all field sampling and testing required by the Field Quality Control article of this section (1.6.4).

## 1.02 RELATED SECTIONS

- A. Masonry: Section 04 00 00.
- B. Sealants: Section 07 92 00.

## 1.03 REFERENCES

- A. Conform to the provisions of the latest editions of the Standards referenced herein, except when standards are modified or supplemented herein.
- B. Standards: The following standards are hereby made a part of this Section and shall govern where applicable except as otherwise specified. Provide one copy of each at job site for reference. Contractor's supervisory personnel shall be thoroughly familiar with this material as it applies to this project.
  - 1. American Concrete Institute (ACI):
    - a. ACI 301, "Specifications for Structural Concrete for Buildings.
    - b. ACI 305, "Hot Weather Concreting."

- c. ACI 306, "Cold Weather Concreting."
- d. ACI 315, "Details and Detailing of Concrete Reinforcement."
- e. ACI 318, "Building Code Requirements for Reinforced Concrete."
- f. ACI 347, "Recommended Practice for Concrete Formwork."
- g. ACI SP-15, "Field Reference Manual."
- h. ACI SP-44, "Fiber Reinforced Concrete."
2. Concrete Reinforcing Steel Institute (CRSI):
  - a. CRSI P-1, "Placing Reinforcing Bars."

C. Reference Standards: Wherever the following abbreviations occur herein, they shall refer to the corresponding standard:

1. ASTM: American Society for Testing and Materials.

#### 1.04 SUBMITTALS

- A. Submit for approval the name of the agency proposed for the required inspection and testing services. If some or all of the required testing is to be performed by personnel not employed by the proposed agency, submit letter from the agency stating that those personnel are qualified to perform the tests.
- B. Submit a mix design for each class of concrete required (1.6.3) Submittals to comply with appropriate methods listed in ACI 301 (4.2.3). Indicate whether mixes have been designed for pumping.
- C. Submit shop drawings for all reinforcing. Indicate strength, size and details of all bar reinforcing and style and specification of all welded wire fabric (3.1.1).
  1. Prepare shop drawings in accordance with ACI 315.
- D. Submit, upon request only, product literature for admixtures and curing compounds proposed for use.
- E. Submit reports of all required testing and inspection.
- F. Submit, on request only, mill test certificate for reinforcing.
- G. Submit test data for aggregates proposed for use, indicating source and compliance with specification requirements. Date of test to be no more than 90 days prior to submittal. Resubmit in advance of any proposed change in source.

#### 1.05 QUALITY ASSURANCE

- A. Layout: Establish and maintain accurate reference points for all concrete surfaces and elevations.
- B. Maintain field records of time, date of placing, curing and removal of forms of concrete in each portion of work. Such records shall be open to inspection, shall

be kept until completion of work and turned over to the Architect.

1.06 FIELD REFERENCE MANUAL

- A. Provide at least one copy of the ACI Field Reference Manual, SP-15, and one copy of CRSI's "Placing Reinforcing Bars" in the field office at all times (1.3.3).

**PART 2 PRODUCTS**

2.01 MATERIALS

- A. Cement: Portland cement, ASTM C150, Type I (4.2.1.1). All cement exposed to public view to be from same mill.
- B. Water: Potable.
- C. Aggregates: ASTM C33.
1. Use crushed limestone for coarse aggregate.
  2. Coarse Aggregate Size
    - a. Thin Sections: No. 67.
    - b. Stair Pans and Floor Topping: No. 7.
    - c. All Others: No. 57.
- D. Admixtures (where required or permitted).
1. Water Reducing: "Eucon WR-75" by the EUCLID CHEMICAL COMPANY, "Pozzolith 200N" by MASTER BUILDERS OR "Plastocrete" by SIKA CHEMICAL CORPORATION. The admixture shall conform to ASTM C4946, Type A and not contain more chloride ions than are present in municipal drinking water. (4.2.1.4).
  2. Air-Entraining: ASTM C260 (4.2.1.4).
  3. High Range Water Reducing Admixture (Superplasticizer): ASTM C494, Type F or G and not contain more chloride ions than are present in municipal drinking water. (4.2.1.4). The following are acceptable:
    - a. Eucon 37 by EUCLID.
    - b. Sikament by SIKA.
    - c. Pozzolith 400-N by MASTER BUILDERS
  4. Fly Ash or Pozzolans: ASTM C618 Class F (4.2.1.1.c). Maximum loss on ignition 3%.
  5. Accelerator: Non-corrosive, non-chloride, ASTM C494, Type C or E, containing no more chlorides than are present in municipal drinking water. The following are acceptable.
    - a. Accelguard 80 by EUCLID.
    - b. Pozzolith 555 - Accelerator by MASTER BUILDERS.
    - c. Plastocrete 161FL by SIKA.
  6. Calcium chloride, thiocyanates or admixtures containing more than 0.05% ions are NOT permitted (4.2.2.6).

7. Upon request only, provide a qualified full-time representative to assure proper use of admixtures.
  8. Use of admixtures other than those listed will be permitted only when approved prior to use.
- E. Reinforcing (3.2.1).
1. Deformed Bars: ASTM A615 (Including Supplementary Requirements), A617 or A706. Minimum yield strength to be 60 ksi, except that bars to be welded are 40 ksi.
  2. Welded Wire Fabric: ASTM A185. Provide in sheet form (not rolls). Where this is used, except in slabs on grade, it is designed as load-carrying reinforcement.
  3. Synthetic Fibers: Monofilament polypropylene fibers for secondary reinforcing of concrete members. Provide one of the following:
    - a. Fiberstrand by EUCLID CHEMICAL COMPANY.
    - b. Fibermesh by FIBERMESH, INC.
    - c. FORTA-FERRO.
- F. Premolded Expansion Joint Filler: ASTM D1751 (2.2.1.4).
- G. Curing and Sealing Compound: Water based type, conforming to ASTM C1315, Type 1, Class A, 25% solids content minimum, and VOC compliant. Manufacturer's certification required. Must be compatible with adhesive specified for floor finishes. EUCLID CHEMICAL COMPANY, CONSPEC, MASTER BUILDERS, SONNEBORN, L& M CHEMICAL.
- H. Grout For Masonry Fill Core: ASTM C476, coarse type.
- I. Non-shrink Grout Under Bearing Elements: Conform to Corps of Engineers Specification CRD-C621. The following are acceptable:
1. Masterflow 713, by MASTER BUILDERS.
  2. SonogROUT by SONNEBORN.
  3. Crystex by L&M CHEMICAL.
  4. N-S Grout, by EUCLID CHEMICAL COMPANY.
  5. Super Flow by UPCON.
- J. Bonding Compound
1. Rewettable: Polyvinyl acetate type. Use in areas not subject to moisture. "Euco Weld" by EUCLID CHEMICAL COMPANY; "Weldcrete" by LARSEN COMPANY.
  2. Non-Rewettable: Polymer modified type. "Euco-Bond" by EUCLID CHEMICAL COMPANY or equal.
- K. Bonding Admixture: Latex, non-wettable type. "SBR Latex" or "FLEX-Con" by

EUCLID CHEMICAL COMPANY or "Daraweld" by W.R. GRACE.

- L. Structural Bonding Epoxy Adhesive: Two component 100% solids, 100% reactive compound suitable for use on dry or damp surfaces. "Euco Epoxy #452MV or #620" by EUCLID CHEMICAL COMPANY or "Sikadur Hi-Mod" by SIKA CHEMICAL CORPORATION.
- M. Form Release: Non-staining, rust preventative, guaranteed not to affect bond of subsequent surface applications to concrete.
- N. Waterstops: Premolded, flexible, polyvinylchloride.
- O. Hardener: Dry shake type. Minimum 50 lbs., per 100 square feet. The following are acceptable.
1. Surfex by EUCLID.
  2. Mastercron by MASTER BUILDERS.
  3. Harcol by SONNEBORN.

## 2.02 MIXES

- A. The following classes of concrete are required (4.2.2.8).

<u>Location</u>	<u>Required 28 Day Compressive Strength, p.s.i.</u>	<u>Maximum Water Cement Ratio</u>	<u>Air Content</u>
Footings, piers, grade beams, caissons and all other below grade	3000	----	optional
Interior slabs on grade, structural slabs, beams, columns, walls	4000	0.50	optional, 3% max. industrial floors
Subjected to freezing and thawing	4000	0.50	4.5 - 7.5%
Exterior slabs subjected to deicers	4500	0.50	4.5 - 7.5%
Reinforced (bars), subjected to deicers, salt spray or brackish water	5000	0.40	4.5 - 7.5%
Exterior topping			

thin sections	4000	0.50	4.5 - 7.5%
Interior stair pans	3000	----	optional

F. Slump

1. Design concrete mixes for a maximum slump of 3 inches for slabs; 4 inches for all other concrete, unless a superplasticizer is to be used.
2. If a superplasticizer is to be used, design mixes for a slump of 2 - 3 inches before its addition; maximum slump permitted after its addition is 6 inches for air-entrained concrete, 8 inches for all other concrete.

**PART 3 EXECUTION**

3.01 SURFACE CONDITIONS

- A. Verify that excavations are free of water and ice, and of the required dimension, and have been approved by the Soils Engineer, prior to placing concrete (5.3.1).
- B. Determine field conditions by actual measurement.
- C. Notify Architect not less than 24 hours in advance of placing concrete. Place concrete only when Architect is present, unless this requirement is specifically waived.

3.02 FORMWORK AND REINFORCING

- A. Footings/Exterior Piers may be cast against earth cuts when soil conditions permit.
- B. Provide camber of 1/4 inch per 16 feet of span in forms for beams, joists and slabs which span more than 12 feet. This camber is to compensate for structural deflection after forms are removed, and is to be in addition to the camber required for formwork deflection.
- C. Reinforcing
  1. Welding of reinforcing is prohibited, except where shown.
  2. Use plastic-tipped bar supports for surfaces exposed to view in finished structure.
- D. Removal of Forms and Shoring
  1. Remove no forms within first 24 hours after placement.
  2. When structure is to be reshored, forms may be removed when the concrete attains 75% of its design strength.
  3. Shoring is to remain in place until concrete reaches its design strength.
  4. Remove all shoring prior to constructing masonry walls supported by the structure.

### 3.03 EMBEDDED ITEMS

#### A. Install embedded conduit, pipes, and sleeves subject to the following limitations:

1. Do not embed aluminum without prior approval of coating material.
2. Do not displace reinforcing steel.
  
3. In slabs limit outside dimension of conduits and pipes to 1/3 member thickness. Where conduits cross, maintain same minimum concrete cover as for reinforcing bars. For slabs over metal deck, thickness is measured from the top of the metal deck.
4. In columns, limit total area of pipes and conduit to 4% of column area.
5. Maintain center-to-center spacing of at least 3 diameters of conduit or pipe.

### 3.04 JOINTING

#### A. Interior Slabs on Grade

1. Locate control and construction joints as shown on the Drawings. In the absence of information on Drawings, locate at openings, walls, columns, grid lines, inside corners and at 12' on center generally. Schedule slab pours and sawcutting operations so that sawing is completed prior to onset of shrinkage cracking (5.3.5).
2. Provide isolation joints at walls (1/4" thick) and at columns (1/2" thick). Where isolation joint will be exposed to view, set top of joint filler below top of slab a distance equal to the filler thickness to receive sealant. Where not exposed to view, set top of filler flush with top of slab.
3. Where joints are exposed to view in the finished building, provide joint sealant.

#### B. Exterior Slabs on Grade: Locate joints as shown on Drawings. In the absence of information on Drawings, provide the following:

1. Expansion Joints: Full depth, with 1/2" joint filler where slabs abut vertical surfaces at intersections of sidewalks, at abrupt changes in width and at a spacing not exceeding 30'.
2. Control Joints: Tooled, 7/8" deep, 4'-0" to 6'-0" o.c. between expansion joints.

### 3.05 FINISHES

#### A. Schedule of finishes on flatwork is as follows:

1. Troweled Finish: Exposed floors; floors to receive adhesive applied finish (5.3.4.2.c).

2. Floated Finish: Interior floor areas to receive finish in cementitious setting bed; exposed top of equipment bases (5.3.4.2.b).
3. Scratched Finish: Surfaces to receive concrete topping (5.3.4.2.a).
4. Broom Finish: Exterior slabs (5.3.4.2.d).

### 3.06 CURING AND PROTECTION

#### A. Temperature

1. When air temperature during placement is less than 40 degrees, or will be within 24 hours, temperature of concrete as placed is to be between 50 and 90 degrees (55 and 90 degrees for sections less than 12" thick). Maintain concrete temperatures within these limits for the full curing period of seven (7) days (4.2.2.7 and 5.3.1.6).

#### B. Curing

1. Interior slab areas which will receive finishes in cementitious setting beds are to be moist cured, without the use of curing compound (5.3.6.4.a through 5.3.6.4.c).
2. All other slab areas may be either moist-cured or receive an application of curing compound (5.3.6.4.e), except that when concrete above grade is placed in the open, and the air temperature exceeds 75 degrees, the concrete is to be moist-cured for the first 24 hours.
3. Whichever curing method is used, it is to commence immediately after disappearance of water sheen, and continue for at least seven (7) days (5.3.6.1). Do not allow curing to be delayed overnight.
4. Prevent excessive moisture loss from formed surfaces (5.3.6.3). If forms are removed before 7 days have elapsed, cure the formed surfaces by moist-curing or application of curing compound for the remainder of the curing period.
5. Exterior slabs and exposed interior slabs are to receive an additional coat of curing compound, prior to completion of construction (two coats if they were moist cured).

### 3.07 CLEANING AND PATCHING

- A. Repair any slabs which do not meet the finish requirements. The Architect will determine whether grinding, filling of cracks or patching and leveling procedures are required.
- B. For slabs which are dusting or showing other signs of improper curing, any corrective measures attempted will be subject to prior approval of the Architect and will be performed at Contractor's expense. These may include additional applications of sealer or liquid hardener, or grinding or covering with a topping.



**3.08 ACCEPTANCE**

- A. Concrete work with serious honeycombing, form misalignment or other deviation from Contract requirements is subject to rejection.
- B. When observations or tests indicate that the Contract requirements have not been met, the Contractor is to bear the costs of all additional testing and analysis to determine acceptability, and also the cost of removal and replacement, if such is required.

**3.09 FIELD QUALITY CONTROL**

- A. Obtain concrete for required tests at point of placement (1.6.4.3).
- B. For each concrete class, perform one strength test for each 100 yards or fraction thereof, placed in any one day (1.6.4.2.d).
- C. Determine slump for each strength test (1.6.4.2.f).
- D. Determine air content for each strength test of air-entrained concrete (1.6.4.2.h).
- E. Determine concrete temperature for each strength test (1.6.4.2.g).
- F. Do not place concrete when slump, air content or temperature varies from allowable (1.6.8).
- G. Maintain records of all tests, indicating exact location of the structure represented by each test.

**END OF SECTION**

**SECTION 08 71 13****AUTOMATIC DOOR OPERATORS****PART 1 GENERAL**

## 1.01 DESCRIPTION

## A. Work Included

1. Automatic door operators, controls and accessories.
  - a. Typical Units: Overhead, surface mounted.
2. Doors specified under Section 08 41 13.
3. Coordination
  - a. Coordinate with finish hardware for compatibility of systems.
  - b. Coordinate required voltages for electric items with voltages supplied under Division 26.
  - c. Coordinate with Section 08 41 13, Aluminum Entrances, to maintain single source responsibility for automatic Door Operators and doors.
4. Include necessary materials, devices and labor required for a complete installation.
5. Electrical work limited to internal system wiring and wiring to activating devices and on/off switches.

## 1.02 RELATED SECTIONS

- A. Sealants: Section 07 92 00.
- B. Aluminum Entrances: Section 08 41 13.
- C. Glass: Section 08 81 00.
- D. Electrical Work: Division 26.
  1. Electrical conduit.
  2. Power source.
  3. Final connection.
  4. Designated electric service.
- E. Door Access Controls : Section 28 13 00.

## 1.03 REFERENCES

- A. American National Standards Institute (ANSI)

1. A156.10: Standard for Power Operated Pedestrian Doors

B. Underwriters' Laboratories (UL)

1. UL325: Electric Door, Drapery, Gate, Louver and Window Operators and Systems.

1.04 SYSTEM DESCRIPTION

A. Automatic Door Operators

1. Location/Type: Overhead, surface mounted, heavy duty, electrically operated.
2. Function: Power assisted opening and closing of door; timing of sequence and hold-open period adjustable.
3. Action: See drawings for direction of swing, hand, etc.

B. Performance Requirements

1. Emergency Exit Doors: Comply with requirements for doors serving as exit components in means of egress, as certified by the manufacturer for the condition shown.
2. Emergency Break Away: Meet requirements of ANSI A156.10.
3. Service Life: Operators to be capable of operating without failure of any component, for not less than 300,000 open and close cycles and wind velocities or equivalent inward differential pressures of 20 mph, with normal maintenance as defined in manufacturer's standard operating manual.
4. Time Delay Setting: Operators adjustable to meet Owner's requirements.
5. Load-Bearing Strength (Wind Resistance): Manufacturer's stock system, adapted to application indicated, tested in accordance with ASTM E330 to withstand at least the following loadings:
  - a. Uniform pressure of 20 psf inward and outward.

1.05 ELECTRIC COORDINATION

A. Power Supplies: Power supplies provided by Division 26 for all electrically operated hardware including the following:

1. Electric door operators.

B. Division 26 Electric Devices: The following electric devices are provided by Division 26:

1. Conduit, relays, transformers.
2. Junction boxes.

C. Voltages and Operation Requirements

1. Operator: 120 VAC.
2. Verify all voltages with Division 16 upon Contract award.

1.06 SUBMITTALS

- A. Submit in accordance with the requirements of the General Conditions and Section 01 33 23.
- B. Shop Drawings: Include complete elevations of the system; details and methods of anchorage; details of construction; finishes; methods of assembly; location and installation of hardware and reinforcement for same; size, shape and thickness of materials; joints and connections; details of joining other work. Show locations of all components.
- C. Product Data: Complete product description. Include all electrical requirements and complete information required for electrical coordination.
- D. Maintenance Data: Furnish written instructions to Owner describing recommended materials and methods for proper maintenance of opener system.
1. Provide adjusting wrenches and other tools necessary for door adjustment and maintenance.
  2. Tag tools for positive identification and deliver to Owner prior to acceptance of work.
- E. Maintenance Agreement
1. Installer shall provide continuing maintenance proposal to Owner for his consideration, in the form of a standard yearly maintenance agreement, starting on date construction contract maintenance requirements are concluded. State services, obligations and terms for agreement period, and for renewal options. Charges for this agreement shall not be part of the base contract price.

1.07 QUALITY ASSURANCE

- A. Subcontract: Subcontract automatic door work to aluminum entrance contractor for proper coordination and single source responsibility where systems abut or connect to one another.
- B. Standards: Provide automatic door operators complying with ANSI A156.10 and UL Standard 325.
- C. Qualifications

1. Manufacturer: Provide units produced by a firm with not less than 5 years successful experience in the fabrication of automatic door equipment of the type required for this project.
2. Installer: Engage an installer who is an authorized representative of the automatic door equipment manufacturer for both the installation and the maintenance of the type of units required for this project.
  - a. Minimum Experience: Not less than 3 years experience in the installation and service of automatic door equipment of the same manufacturer.
  - b. Maintenance Proximity: Not more than 1 hour normal travel time from Installer's place of business to project site.

#### 1.07 PRODUCT DELIVERY, STORAGE AND HANDLING

- A. Store materials at job site so as to prevent damage to members or assemblies, and protect from corrosion or deterioration.

#### 1.08 WARRANTY

- A. Contractor(s): Provide a 2 year guarantee on all systems.
  1. Warrant systems free of defects due to faulty materials and workmanship.
  2. Include repair and replacement of defective materials and components at no additional cost to the Owner.

### **PART 2 PRODUCTS**

#### 2.01 MANUFACTURERS

- A. Provide conforming products from one of the following:
  1. BESAM
  2. STANLEY
  3. DOR-O-MATIC

#### 2.02 MATERIALS

- A. Exposed Metal
  1. Aluminum Extrusions and Aluminum Sheet
    - a. Compatible with specified finish.
  2. Provide aluminum alloy and temper for each shape, as recommended by manufacturer and processor to comply with the requirements of performance, fabrication, application of finish, and control of color.

- B. Aluminum Thickness
  - 1. Section thickness to meet design requirements.
  - 2. Moldings, Trim and Glass Stops: 0.05 inch minimum.
- C. Concealed Metals: Manufacturer's standard, suitable for application.
- D. Steel Reinforcements and Brackets: Manufacturer's standard units with 2.0 ounce hot-dip galvanized coating, ASTM A653. Applied after fabrication.
- E. Fasteners: Aluminum, non-magnetic stainless steel, or other noncorrosive metal compatible with the items being fastened. For exposed fasteners, provide Phillips flat-head screws with finish matching the item fastened.
- F. Sealants and Gaskets: Manufacturer's standard.
- G. Bituminous Coatings: Cold applied asphalt mastic, SSPC-PAINT 12.

### 2.03 AUTOMATIC DOOR OPENER

- A. Specification based on electric swing door system by BESAM, Model 450, overhead, surface mounted. See Part 1, Performance Requirements.
- B. Operator Location: Controls and connecting hardware to mount above door frame; provide with removable aluminum access cover in front.
  - 1. Housing: Nominal 6" x 6" with finished end caps; See Materials hereinbefore. Minimum aluminum thickness 0.146 inch.
- C. Operator Function: Manufacturer's standard electrical unit, powered in the opening cycle, spring return in the closing cycle and with speed control to provide checking in both cycles.
  - 1. Provide for manual operation when power is off, and provide emergency release for manual swing-out action of doors that are indicated to function as exits.
  - 2. Equip units with hold-open switch, arranged to hold door open without the continued use of power.
- D. Operator Action: As indicated by door swing on drawings (swing-in, swing-out, double swing, pairs, etc.).
- E. Electrical Control: Self-contained unit including necessary transformers, relays, rectifiers, and other electronic components for proper operation and switching of power operator.
  - 1. Relays: Plug-in type for individual replacement.
  - 2. Connecting Harnesses: Provide with interlocking plugs.

3. Provide control with adjustable time delay module of 0-60 seconds.

F. Hardware

1. Manufacturer's standard arm and track device or direct connection to center pivots.
2. Keyed Switch: Manufacturer's standard key operated on/off switch; cylinder furnished under Section 08 71 00, Finish Hardware.

2.04 ACTUATING CONTROLS

- A. Push Button: Provide 6" diameter stainless steel push button switch with handicapped insignia. Locate interior control button on wall as indicated.

2.05 HARDWARE

- A. Provide hardware necessary for complete installation.
- B. Automatic door opener supplier to coordinate all door preparation for hardware scheduled under Section 08 41 13, Aluminum Entrances.

2.06 ACCESSORIES

- A. Marking: Provide caution decals on automatic doors in conformance with ANSI A156.10.
- B. Miscellaneous: As required for complete installation.

2.07 FABRICATION

- A. General
1. Sizes and Profiles: Required sizes for door and frame units, including profile requirements, as specified and as indicated on drawings.
  2. Welding: Comply with AWS recommendations to avoid discoloration at welds; grind exposed welds smooth and restore mechanical finish.
  3. Conceal fasteners where possible.
  4. Maintain continuity of line and accurate relation of planes and angles. Provide secure attachment and support at mechanical joints, with hairline fit of contacting members.
  5. Reinforce the work as necessary for performance requirements, and for support to the structure. Separate dissimilar metals with bituminous paint or preformed separators. Separate metal surfaces at moving joints with non-metallic separators to prevent "freeze-up" of joints.
  6. Weatherstripping: Where exterior door stiles or head rails do not close

against fixed stops equipped with weatherstripping, provide weatherstripping, retained in an adjustable strip in a mortise centered in the edge of the door.

- B. Aluminum Door and Sidelight Framing: Provided under Section 08 41 13, Aluminum Entrances. See Part 1, Description, for coordination with other products.

**PART 3 EXECUTION**

3.01 EXAMINATION

- A. Examine substrates to which work of this Section applies. No work shall be installed until corrections to substrates have been performed by trades involved.

3.02 INSTALLATION

- A. Install in accordance with manufacturer's instructions and recommendations and in compliance with referenced standards. Members shall be level, square, plumb, at proper elevations and in alignment with other work. Attach and secure to structure as required to assure stability of system.
- B. Provide wiring from activating devices, controls, and remote on/off switches in conduit provided under Division 26.
- C. All units to be free and smoothly operating without binding or rough spots; adjust as required and/or replace improperly functioning units.
- D. After repeated operation of completed installation equivalent to three days use by normal traffic (100 to 300 cycles), readjust door operators and controls for optimum operating conditions and safety. Lubricate operating equipment and clean exposed surfaces.
- E. Provide protective measures and other precautions required to ensure that automatic entrance doors will be without damage or deterioration, other than normal weathering, at time of substantial completion.

**END OF SECTION**



**SECTION 12 48 23****ENTRANCE FLOOR GRIDS****PART 1 GENERAL**

## 1.01 WORK INCLUDED

- A. Provide recessed entrance grid mats and frames.

## 1.02 SUBMITTALS

- A. Shop Drawings: Submit product data and layout drawings in accordance with the General Conditions. Provide data on both mat and frame, including dimensioned plan of frame recess.
- B. Samples: Provide 2 samples of entrance floor mat 4" x 8"; and 2 color charts of manufacturer's standard colors.

## 1.03 JOB CONDITIONS

- A. Coordination: Coordinate concrete slab placement with installation of recessed frame. Verify location, shape and size of mat.

**PART 2 PRODUCTS**

## 2.01 MATERIALS

- A. Entrance Floor Mat: BALCO, SSMR-118 Type 304 Stainless Steel Entrance Grate or equal by MM SYSTEMS CORPORATION CONSTRUCTION SPECIALTIES, MM SYSTEMS CORPORATION; ARDEN ENTRANCE MATS or REESE ENTERPRISES. Including the following:
1. Material: Mill Finish Stainless Steel.
  2. Description: Recessed mat consisting of interlocking tread rails, frame (mitered and positive locked), and continuous resilient bearing cushions.
  3. Construction: Series of tread rails continuously hinged together running counter to traffic flow. Frames and tread rails within 1 1/4" (nominal) recess depth.
  4. Size: As indicated on drawings.

**PART 3 EXECUTION**

3.01           INSTALLATION

- A.    Verify mat recess dimensions before fabrication of mat. Place mat loose in applicable recess. Coordinate installation of recessed frame with floor slab pour.
- B.    Install mat in locations indicated on drawings per manufacturer's instructions.

**END OF SECTION**

**SECTION 10 14 10****INTERIOR SIGNAGE****PART 1 GENERAL****1.01 WORK INCLUDED****A. Work includes:**

1. Room numbers/Room identification
2. Restrooms
  - a. Wheel Chair Accessible
  - b. Non-Accessible
3. Stairwell identification.
4. Floor identification (stairwell).
5. Directional/Informational signs.
6. Elevator door jamb plate (floor numbering).
7. Emergency escape directories.
8. Posted occupancy limit.
9. Elevator fire emergency plaque.

- B.** All signs which identify permanent facilities/accommodations shall be tactile and braille and limited minimally to room numbers, restrooms, stairways, floor identification, elevators and room names as deemed appropriate by the Owner.

**1.02 SUBMITTALS**

- A.** Shop Drawings: Submit manufacturer's product data, where applicable, and complete drawings showing all identifying devices and installation details in accordance with the requirements of the General Conditions.
- B.** Samples: Submit samples for materials, finishes, colors, letter styles, etc., as required for selection and approval by Architect prior to fabrication of identifying devices.
- C.** Final signage schedule must be approved by Owner prior to fabrication. Submittal to Owner should be made through the Architect.

**1.03 QUALITY ASSURANCE**

- A.** Signage Standards: Conform to the Americans with Disabilities Act (ADA) Standards where applicable and to the extent as indicated.

- B. Acceptable Manufacturers: All units are to be custom fabricated; manufacturer's products meeting the specifications will be acceptable. Manufacturers must be regularly engaged in fabrication and installation of signage units and related identifying devices.
  - 1. Fabricator shall make at least one visit to the site before production begins to review all sign locations and installation conditions with Architect and Owner's representative.
  - 2. Fabricator must review all dimensional changes with Architect.
- C. Approvals: All identifying devices shall be approved at the fabricator's shop by the Architect prior to shipment and installation.
- D. Spelling and Braille Accuracy: Responsibility of sign manufacturer.
- E. The Owner has the right to renumber the room numbers during construction. Manufacturer must not begin fabrication of room number plates until room numbers have been approved by the Owner, in writing, through the Architect.
- F. Room identifications will be provided to the Contractor by the Owner during construction.

#### 1.04 DELIVERY, STORAGE AND HANDLING

- A. Deliver materials in manufacturer's original shipping cartons with seals unbroken.
- B. Protect materials from physical damage.
- C. Store materials in clean, dry area.
- D. Inspect all materials prior to installation to assure proper function and condition of all items.

### **PART 2 PRODUCTS**

#### 2.01 GENERAL REQUIREMENTS

- A. Locations, Quantities, Graphics and Copy: As indicated on drawings and/or specified (scheduled) herein.

#### 2.02 MATERIALS

- A. Plates: High pressure phenolic "ES" plastic; scratch resistant, non-static, thermoset, rated self-extinguishing.
  - 1. Colors: As selected by Architect.
  - 2. Thickness: 3/32" for ADA plates; 1/16" for non-raised copy (flat) plates.

- B. Changeable Copy: Provide 3/32" thick plastic back-up plate laminated to back of face plate to create slot for removable nameplates.
- C. Provide an integral method to create tactile and Braille signs; producing a unitary component. Glued on or laminated letters or Braille cells are not acceptable.

### 2.03 DESIGN GUIDELINES

- A. Plate Shape: Square cornered; do not bevel edges.
- B. Letter Style
  - 1. ADA Signs: Helvetica medium, all capital letters.
  - 2. All Other Signs: Helvetica medium, mixed upper and lower case.
- C. Tactile Letters and Braille: Grade II braille; raised 1/32" above background surface. Provide Braille dome topped same color as background. Sign manufacturer shall be responsible for verifying accuracy of spelling, both tactile and Braille.
- D. Letter Size
  - 1. Tactile Signs: Minimum letter size is 5/8" for capital letters. Room numbers to be 1 1/4".
  - 2. Non-tactile Signs: Between 3/8" and 1" capital letter height. Larger letters are permitted on directional signs or on signs where reading distance is greater than 15'-0".
  - 3. Overhead Signs: Minimum 3" copy. Mixed upper and lower case is permissible. Non-tactile is permissible.

### 2.04 METHOD OF MANUFACTURING

- A. Tactile Signs: Relief engraved plates.
- B. Non-Tactile Signs: Routed engraved.

### 2.05 SIGNS REQUIRED FOR TACTILE/BRAILLE

- A. Room Numbers/Room Identification:
  - 1. Size determined by copy requirements, laid out flush left with 3/4" margin on left, room name in 5/8" caps with Braille directly below type copy, all flush left.
- B. Restrooms - Wheel Chair Accessible: Approximately 9" wide x 9" high plate with 1" capital letters (MEN or WOMEN), centered on the plate with Braille directly below the copy. Provide a routed engraved wheel chair access symbol and a universal man or woman symbol located above the word. No border.

- C. Stairwell Identification: 9" x 9" plate with 1" capital letters laid out flush left with 3/4" margin on left. Braille directly below the type copy.
- D. Floor Identification - Inside Stairwells: 9" x 9" plate with 1" capital letters (1st FLOOR, 2nd FLOOR, etc.) laid out flush left with 3/4" margin on left . Braille directly below the type copy.
- E. Directional/Informational Signs: Wall mounted; non-tactile; in upper and lower case. Letter height shall be at least 1" cap height for directional signs. Letter sizes for informational signs may be less than 1".
- F. Elevator Door Jamb Plate: 3-3/4" x 3-3/4" plate with 2" numerals centered horizontally on plate with Braille centered directly below numerals.

## 2.06 SIGNS REQUIRED FOR NON-TACTILE/BRAILLE SIGNAGE

- A. Plate Shape: Square cornered; do not bevel edges.
- B. Plate Heights
  - 1. 2-1/4" for one line of copy.
  - 2. 3-3/4" for two lines of copy.
  - 3. 5-1/4" for three lines of copy.
- C. Changeable Copy Plates
  - 1. Height: Same as in "2.05 A" above.
  - 2. Length: VARIES
  - 3. Face openings of slot: 1" high with 3/4" margin at ends and bottom.
  - 4. Allow 1/2" vertically between slot openings.
  - 5. Slots behind openings: Allow for 1-1/4" wide x 1/16" thick blank changeable copy strips supplied by the Contractor for future engraving by Owner.
  - 6. Tactile room numbers with Braille may appear on the face of the sign frame.

## 2.07 EMERGENCY ESCAPE DIRECTORY

- A. Description: 18" x 12". Extruded aluminum "F" frame with anodized medium bronze finish and non-glare acrylic face. Provide with rigid masonite backing.
- B. Copy: Color screen printed removable graphic of floor plan showing escape route from installed location. Locate at elevators and stair doors at each floor, and at building main entrance.

## 2.08 POSTED OCCUPANCY LIMIT

- A. Posted Occupancy Limit: Provide sign reading, "Maximum Occupants Permitted This Space". Provide signage in accordance with OBC 1004 "Posting of Occupant Load". Locate signs as indicated on drawings (sign type L)

2.10 ELEVATOR FIRE EMERGENCY PLAQUE

- A. Description: Approximately 9" x 9". Text to read, "In Case of Fire Use Stairs" in 1" letters with Braille centered below. Graphics to include international wheelchair and stair symbols.

**2.11 COPY POSITION**

- A. Lines of copy laid out flush left with a margin of 3/4" along the left edge of plate. Exceptions are small room numbers, restrooms and stairways shall be centered on the plate.
- B. Left hand, right hand and bottom margins are 3/4". Vertical spacing measured between lower case letters is 3/4". Overall width and height of a plate is achieved with multiples of 3/4".
- C. Locate directional arrows in upper left hand corner of plate. Arrows count as one line of copy.

**PART 3 EXECUTION****3.01 INSTALLATION**

- A. Mount signs plumb and level.
- B. Mount all identification devices with 3/4" foam tape on all four edges.

**3.02 SIGNAGE SCHEDULE**

- A. Provide the following Sign Plates
  - 1. Room Identification Signs: As noted on drawings as sign types E.3 or J.
  - 2. Women, combined with room number and handicap symbol and international symbol, as applicable, at each restroom. As noted on drawings as sign type E.2W
  - 3. Men, combined with room number and handicap symbol and international symbol, as applicable, at each restroom. As noted on drawings as sign type E.2M
- B. Stairwell Identification: Provide at all stair doors as noted on drawings as sign type E.1
- C. Floor Identification: Provide inside stairwell at all stair doors as noted on drawings as sign type N.
- D. Elevator Fire Emergency Plaque: Provide at each elevator stop as noted on drawings as sign type D.2.
- F. Elevator Door Jamb Plates: Two plates required per elevator door, one on each side of the jamb.
- E. Emergency Escape Directory: As noted on drawings as sign type D.1.





- F. Directional/Informational Signs: For bidding purposes, provide one per stair door on each floor and an additional one per lobby and vestibules on the entry floor. Each sign will contain 25 symbols/characters arranged in two lines. Locate as directed by Architect. As noted on drawings as sign type B.
- G. Posted Occupancy Limit: As noted on drawings as sign type L
- H. Sign Locations
  - 1. Single Doors: Locate signs on the wall next to the latch side of the door, 1" from the outside edge of the door frame and with the top edge of the uppermost sign 61-1/2" A.F.F.
  - 2. Pairs of Doors: Locate signs as specified above for single doors, except Architect will direct in field if sign occurs on right or left jamb of opening.
  - 3. Doors with Borrowed Lights: Locate as directed by Architect.

### 3.03 CLEAN UP

- A. After completion of work remove all debris and tools from the premises, clean all adhesive spatter and run-over from finished surfaces and wash all plated clean of fingermarks and soil. Polish sign surfaces with a soft cotton rag.

**END OF SECTION**

## SECTION 237313 - MODULAR INDOOR CENTRAL-STATION AIR-HANDLING UNITS

## PART 1 - GENERAL

## 1.1 RELATED DOCUMENTS

- A. Drawings and general provisions of the Contract, including General and Supplementary Conditions and Division 01 Specification Sections, apply to this Section.

## 1.2 SUMMARY

- A. Section Includes:

1. Constant-air-volume, single-zone air-handling units.
2. Variable-air-volume, single-zone air-handling units.

## 1.3 PERFORMANCE REQUIREMENTS

- A. Delegated Design: Design vibration isolation and seismic-restraint details, including comprehensive engineering analysis by a qualified professional engineer, using performance requirements and design criteria indicated.
- B. Structural Performance: Casing panels shall be self-supporting and capable of withstanding 133 percent of internal static pressures indicated, without panel joints exceeding a deflection of  $L/100$  where "L" is the unsupported span length within completed casings.

## 1.4 ACTION SUBMITTALS

- A. Product Data: For each air-handling unit indicated.

1. Unit dimensions and weight.
2. Cabinet material, metal thickness, finishes, insulation, and accessories.
3. Fans:
  - a. Certified fan-performance curves with system operating conditions indicated.
  - b. Certified fan-sound power ratings.
  - c. Fan construction and accessories.
  - d. Motor ratings, electrical characteristics, and motor accessories.
4. Certified coil-performance ratings with system operating conditions indicated.
5. Dampers, including housings, linkages, and operators.
6. Filters with performance characteristics.

### 1.5 INFORMATIONAL SUBMITTALS

- A. Coordination Drawings: Floor plans and other details, drawn to scale, on which the following items are shown and coordinated with each other, using input from installers of the items involved:
  - 1. Mechanical-room layout and relationships between components and adjacent structural and mechanical elements.
  - 2. Support location, type, and weight.
  - 3. Field measurements.
- B. Source quality-control reports.
- C. Field quality-control reports.

### 1.6 CLOSEOUT SUBMITTALS

- A. Operation and Maintenance Data: For air-handling units to include in emergency, operation, and maintenance manuals.

### 1.7 MAINTENANCE MATERIAL SUBMITTALS

- A. Furnish extra materials that match products installed and that are packaged with protective covering for storage and identified with labels describing contents.
  - 1. Filters: One set(s) for each air-handling unit.
  - 2. Gaskets: One set(s) for each access door.
  - 3. Fan Belts: One set(s) for each air-handling unit fan.

### 1.8 QUALITY ASSURANCE

- A. Electrical Components, Devices, and Accessories: Listed and labeled as defined in NFPA 70, by a qualified testing agency, and marked for intended location and application.
- B. NFPA Compliance: Comply with NFPA 90A for design, fabrication, and installation of air-handling units and components.
- C. ARI Certification: Air-handling units and their components shall be factory tested according to ARI 430, "Central-Station Air-Handling Units," and shall be listed and labeled by ARI.
- D. ASHRAE Compliance: Applicable requirements in ASHRAE 62.1, Section 5 - "Systems and Equipment" and Section 7 - "Construction and Startup."
- E. ASHRAE/IESNA 90.1 Compliance: Applicable requirements in ASHRAE/IESNA 90.1, Section 6 - "Heating, Ventilating, and Air-Conditioning."
- F. Comply with NFPA 70.

## 1.9 COORDINATION

- A. Coordinate sizes and locations of concrete bases with actual equipment provided.
- B. Coordinate sizes and locations of structural-steel support members, if any, with actual equipment provided.

## PART 2 - PRODUCTS

## 2.1 MANUFACTURERS

- A. Manufacturers: Subject to compliance with requirements, available manufacturers offering products that may be incorporated into the Work include, but are not limited to, the following:
  - 1. Carrier Corporation; a member of the United Technologies Corporation Family.
  - 2. Coil Company, LLC.
  - 3. McQuay International
  - 4. Trane; American Standard Inc.
  - 5. USA Coil & Air.
  - 6. Johnson Controls

## 2.2 UNIT CASINGS

- A. General Fabrication Requirements for Casings:
  - 1. Forming: Form walls, roofs, and floors with at least two breaks at each joint.
  - 2. Casing Joints: Sheet metal screws or pop rivets.
  - 3. Sealing: Seal all joints with water-resistant sealant.
  - 4. Factory Finish for Steel Casings: Apply manufacturer's standard primer immediately after cleaning and pretreating.
  - 5. Factory Finish for Steel Casings: Immediately after cleaning and pretreating, apply manufacturer's standard two-coat, baked-on enamel finish, consisting of prime coat and thermosetting topcoat.
  - 6. Casing Coating: Powder-baked enamel.
  - 7. Airstream Surfaces: Surfaces in contact with the airstream shall comply with requirements in ASHRAE 62.1.
- B. Casing Insulation and Adhesive:
  - 1. Materials: ASTM C 1071, Type I.
  - 2. Location and Application: Factory applied with adhesive and mechanical fasteners to the internal surface of section panels downstream from, and including, the cooling-coil section.
    - a. Liner Adhesive: Comply with ASTM C 916, Type I.
    - b. Mechanical Fasteners: Galvanized steel, suitable for adhesive attachment, mechanical attachment, or welding attachment to duct without damaging liner

when applied as recommended by manufacturer and without causing leakage in cabinet.

- c. Liner materials applied in this location shall have air-stream surface coated with a temperature-resistant coating or faced with a plain or coated fibrous mat or fabric depending on service-air velocity.

3. Location and Application: Encased between outside and inside casing.

C. Inspection and Access Panels and Access Doors:

1. Panel and Door Fabrication: Formed and reinforced, single- or double-wall and insulated panels of same materials and thicknesses as casing.
2. Inspection and Access Panels:
  - a. Fasteners: Two or more camlock type for panel lift-out operation. Arrangement shall allow panels to be opened against air-pressure differential.
  - b. Gasket: Neoprene, applied around entire perimeters of panel frames.
  - c. Size: Large enough to allow inspection and maintenance of air-handling unit's internal components.
3. Access Doors:
  - a. Hinges: A minimum of two ball-bearing hinges or stainless-steel piano hinge and two wedge-lever-type latches, operable from inside and outside. Arrange doors to be opened against air-pressure differential.
  - b. Gasket: Neoprene, applied around entire perimeters of panel frames.
  - c. Size: At least 24 inches wide by full height of unit casing up to a maximum height of 60 inches
4. Locations and Applications:
  - a. Fan Section: Doors.
  - b. Access Section: Doors.
  - c. Coil Section: Inspection and access panel.
  - d. Damper Section: Doors.
  - e. Filter Section: Doors large enough to allow periodic removal and installation of filters.
  - f. Mixing Section: Doors.
  - g. Humidifier Section: Doors.

D. Condensate Drain Pans:

1. Fabricated with one percent slope in at least two planes to collect condensate from cooling coils (including coil piping connections, coil headers, and return bends) and from humidifiers and to direct water toward drain connection.
  - a. Length: Extend drain pan downstream from leaving face to comply with ASHRAE 62.
  - b. Depth: A minimum of 2 inches deep.

2. Integral part of floor plating.
3. Single-wall, stainless-steel sheet.
4. Drain Connection: Located at lowest point of pan and sized to prevent overflow. Terminate with threaded nipple on one end of pan.
  - a. Minimum Connection Size: NPS 1

- E. Air-Handling-Unit Mounting Frame: Formed galvanized-steel channel or structural channel supports, designed for low deflection, welded with integral lifting lugs.

### 2.3 FAN, DRIVE, AND MOTOR SECTION

- A. Fan and Drive Assemblies: Statically and dynamically balanced and designed for continuous operation at maximum-rated fan speed and motor horsepower.

1. Shafts: Designed for continuous operation at maximum-rated fan speed and motor horsepower, and with field-adjustable alignment.
  - a. Turned, ground, and polished hot-rolled steel with keyway. Ship with a protective coating of lubricating oil.
  - b. Designed to operate at no more than 70 percent of first critical speed at top of fan's speed range.

- B. Centrifugal Fan Housings: Formed- and reinforced-steel panels to form curved scroll housings with shaped cutoff and spun-metal inlet bell.

1. Bracing: Steel angle or channel supports for mounting and supporting fan scroll, wheel, motor, and accessories.
2. Horizontal-Flanged, Split Housing: Bolted construction.
3. Housing for Supply Fan: Attach housing to fan-section casing with metal-edged flexible duct connector.
4. Flexible Connector: Factory fabricated with a fabric strip 5-3/4 inches wide attached to 2 strips of 2-3/4-inch- wide, 0.028-inch- thick, galvanized-steel sheet or 0.032-inch- thick aluminum sheets; select metal compatible with casing.
  - a. Flexible Connector Fabric: Glass fabric, double coated with neoprene. Fabrics, coatings, and adhesives shall comply with UL 181, Class 1.
    - 1) Fabric Minimum Weight: 26 oz./sq. yd..
    - 2) Fabric Tensile Strength: 480 lbf/inch in the warp and 360 lbf/inch in the filling.
    - 3) Fabric Service Temperature: Minus 40 to plus 200 deg F.

- C. Airfoil, Centrifugal Fan Wheels: Smooth-curved inlet flange, backplate, and hollow die-formed airfoil-shaped blades continuously welded at tip flange and backplate; cast-iron or cast-steel hub riveted to backplate and fastened to shaft with set screws.

- D. Fan Shaft Bearings:

1. Prelubricated and Sealed, Ball Bearings: Self-aligning, pillow-block type with a rated life of 120,000 hours according to ABMA 9.
  2. Grease-Lubricated, Tapered-Roller Bearings: Self-aligning, pillow-block type with double-locking collars and 2-piece, cast-iron housing with grease lines extended to outside unit and a rated life of 120,000 hours according to ABMA 11.
- E. Belt Drives: Factory mounted, with adjustable alignment and belt tensioning, and with 1.5 service factor based on fan motor.
1. Pulleys: Cast iron or cast steel with split, tapered bushing; dynamically balanced at factory.
  2. Motor Pulleys: Adjustable pitch for use with 5-hp motors and smaller; fixed pitch for use with motors larger than 5hp. Select pulley size so pitch adjustment is at the middle of adjustment range at fan design conditions.
  3. Belts: Oil resistant, nonsparking, and nonstatic; in matched sets for multiple-belt drives.
  4. Belt Guards: Comply with requirements specified by OSHA and fabricate according to SMACNA's "HVAC Duct Construction Standards"; 0.1046-inch- thick, 3/4-inch diamond-mesh wire screen, welded to steel angle frame; prime coated.
- F. Variable-Inlet Vanes: Steel, with blades supported at both ends with permanently lubricated bearings. Variable mechanism terminating in single lever for connection to control actuator with connecting shaft for second set of variable inlet vanes on double-width fans.
- G. Internal Vibration Isolation: Fans shall be factory mounted with manufacturer's standard vibration isolation mounting devices having a minimum static deflection of 1 inch.
- H. Motor: Comply with NEMA designation, temperature rating, service factor, enclosure type, and efficiency requirements for motors specified in Section 230513 "Common Motor Requirements for HVAC Equipment."
1. Enclosure Type: Totally enclosed, fan cooled.
  2. NEMA Premium (TM) efficient motors as defined in NEMA MG 1.
  3. Motor Sizes: Minimum size as indicated. If not indicated, large enough so driven load will not require motor to operate in service factor range above 1.0.
  4. Controllers, Electrical Devices, and Wiring: Comply with requirements for electrical devices and connections specified in electrical Sections.
  5. Mount unit-mounted disconnect switches on exterior of unit.

## 2.4 COIL SECTION

### A. General Requirements for Coil Section:

1. Comply with ARI 410.
2. Fabricate coil section to allow removal and replacement of coil for maintenance and to allow in-place access for service and maintenance of coil(s).
3. For multizone units, provide air deflectors and air baffles to balance airflow across coils.
4. Coils shall not act as structural component of unit.



- B. Water and steam coil capacity and pressure drop performance will be certified in accordance with AHRI Standard 410, when selected within fluid velocity, inlet fluid temperature, and entering air temperature ranges specified by AHRI 410.
- C. Cooling coil segments will have a full-width IAQ drain pan that extends at least 6” downstream of the last coil in the section.
- D. Coils will be removable from the side of unit, via removable AHU panels. No more than one panel must be removed to remove a coil.
- E. Coils will have frames constructed of galvanized steel. Casing channels will be free-draining and do not block fin area.
- F. Cooling coils with finned height greater than 48” will have an intermediate drain pan with downspout to drain condensate to main drain pan. Intermediate drain pan material will match coil frame material.
- G. Coil segment door clearances will allow for at least 2-inches of field installed piping insulation.
- H. Coil bulkheads and blank-offs will prevent air from bypassing coils.
- I. Coil segment casing to accommodate full-face or reduced-face coils will be provided. Provide face and bypass coil segments with factory installed bypass damper
- J. A 1/4" FPT plugged vent/drain tap will be provided on each connection. Vent, drain, and coil connections will be extended to outside of AHU casing.
- K. Staggered Coil bank will be provided. A 1/4" FPT plugged vent/drain tap will be provided on each connection. Vent, drain, and coil connections will be supplied within 10” of the header.
- L. Spool shaped coil grommets will be provided to insulate and seal coil penetrations.
- M. Water coils will be designed to operate at 250 psig and up to 300° F and will be factory tested with 325 psig compressed air under water.
- N. Steam distributing coils will be designed for operation at 50 psig pressure, and a corresponding saturated steam temperature of 298° F. Coils will be factory tested with 315 psig compressed air under water. Coils will be dehydrated and sealed prior to shipping.
- O. Water coil tubes will be mandrel expanded to form fin bond and burnished, work-hardened interior surface.
- P. Steam coil tubes will have outer tube outside diameter of 1" and inner distribution tube outside diameter of 5/8". Circuiting will be non-trapping, drainable, suitable for a gravity drain. Steam will discharge in direction of condensate flow to ensure even heat transfer across each tube.
- Q. Coil fins will be die-formed, continuous aluminum and have fully drawn collars to accurately space fins, and form a protective sheath for tubes.

## 2.5 AIR FILTRATION SECTION

### A. General Requirements for Air Filtration Section:

1. Comply with NFPA 90A.
2. Provide minimum arrestance according to ASHRAE 52.1, and a minimum efficiency reporting value (MERV) according to ASHRAE 52.2.
3. Provide filter holding frames arranged for flat or angular orientation, with access doors on both sides of unit. Filters shall be removable from one side or lifted out from access plenum.

### B. Extended-Surface, Disposable Panel Filters:

1. Factory-fabricated, dry, extended-surface type.
2. Thickness: 4 inches.
3. Initial Resistance: 0.65inches wg..
4. Recommended Final Resistance: 1 inch wg.
5. Arrestance (ASHRAE 52.1): 90.
6. Merv (ASHRAE 52.2): 13.
7. Media: Fibrous material formed into deep-V-shaped pleats with antimicrobial agent and held by self-supporting wire grid.
8. Media-Grid Frame: Nonflammable cardboard.
9. Mounting Frames: Welded, galvanized steel, with gaskets and fasteners, suitable for bolting together into built-up filter banks.

### C. Filter Gage:

1. 2-inch- diameter, diaphragm-actuated dial in metal case.
2. Vent valves.
3. Black figures on white background.
4. Front recalibration adjustment.
5. 3 percent of full-scale accuracy.
6. Range: 0- to 2.0-inch wg.
7. Accessories: Static-pressure tips with integral compression fittings, 1/4-inch plastic tubing, and 2- or 3-way vent valves.

## 2.6 DAMPERS

### A. General Requirements for Dampers: Leakage rate, according to AMCA 500, "Laboratory Methods for Testing Dampers for Rating," shall not exceed 2 percent of air quantity at 2000-fpm face velocity through damper and 4-inch wg pressure differential.

### B. Damper Operators: Comply with requirements in Section 230900 "Instrumentation and Control for HVAC."

### C. Electronic Damper Operators:

1. Direct-coupled type designed for minimum 60,000 full-stroke cycles at rated torque.

2. Electronic damper position indicator shall have visual scale indicating percent of travel and 2- to 10-V dc, feedback signal.
  3. Operator Motors:
    - a. Comply with NEMA designation, temperature rating, service factor, enclosure type, and efficiency requirements for motors specified in Section 230513 "Common Motor Requirements for HVAC Equipment."
    - b. Size to operate with sufficient reserve power to provide smooth modulating action or two-position action.
    - c. Permanent Split-Capacitor or Shaded-Pole Type: Gear trains completely oil immersed and sealed. Equip spring-return motors with integral spiral-spring mechanism in housings designed for easy removal for service or adjustment of limit switches, auxiliary switches, or feedback potentiometer.
  4. Nonspring-Return Motors for Dampers Larger Than 25 Sq. Ft.: Size for running torque of 150 in. x lbf and breakaway torque of 300 in. x lbf.
  5. Spring-Return Motors for Dampers Larger Than 25 Sq. Ft.: Size for running and breakaway torque of 150 in. x lbf.
  6. Size dampers for running torque calculated as follows:
    - a. Parallel-Blade Damper with Edge Seals: 7 inch-lb/sq. ft. of damper.
    - b. Opposed-Blade Damper with Edge Seals: 5 inch-lb/sq. ft. of damper.
    - c. Parallel-Blade Damper without Edge Seals: 4 inch-lb/sq. ft. of damper.
    - d. Opposed-Blade Damper without Edge Seals: 3 inch-lb/sq. ft. of damper.
    - e. Dampers with 2- to 3-Inch wg of Pressure Drop or Face Velocities of 1000 to 2500 fpm: Increase running torque by 1.5.
    - f. Dampers with 3- to 4-Inch wg of Pressure Drop or Face Velocities of 2500 to 3000 fpm: Increase running torque by 2.0.
  7. Coupling: V-bolt and V-shaped, toothed cradle.
  8. Overload Protection: Electronic overload or digital rotation-sensing circuitry.
  9. Fail-Safe Operation: Mechanical, spring-return mechanism with external, manual gear release on nonspring-return actuators.
  10. Power Requirements (Two-Position Spring Return): -V ac.
  11. Power Requirements (Modulating): Maximum 10 VA at 24-V ac or 8 W at 24-V dc.
  12. Proportional Signal: 2- to 10-V dc or 4 to 20 mA, and 2- to 10-V dc position feedback signal.
  13. Temperature Rating: Minus 22 to plus 122 deg F.
  14. Run Time: 12 seconds open, 5 seconds closed.
- D. Outdoor-Air Dampers: Low-leakage, double-skin, airfoil-blade, galvanized-steel dampers with compressible jamb seals and extruded-vinyl blade edge seals in parallel-blade arrangement with cadmium-plated steel operating rods rotating in stainless-steel sleeve bearings mounted in a single galvanized-steel frame, and with operating rods connected with a common linkage. Leakage rate shall not exceed 5 cfm/sq. ft. at 1-inch wg and 9 cfm/sq. ft. at 4-inch wg.
- E. Mixing Section: Multiple-blade, air-mixer assembly located immediately downstream of mixing section.
- F. Combination Filter and Mixing Section:

1. Cabinet support members shall hold 2-inch- thick, pleated, flat, permanent or throwaway filters.
2. Multiple-blade, air-mixer assembly shall mix air to prevent stratification, located immediately downstream of mixing box.

## 2.7 SOURCE QUALITY CONTROL

- A. Fan Sound-Power Level Ratings: Comply with AMCA 301, "Methods for Calculating Fan Sound Ratings from Laboratory Test Data." Test fans according to AMCA 300, "Reverberant Room Method for Sound Testing of Fans." Fans shall bear AMCA-certified sound ratings seal.
- B. Fan Performance Rating: Factory test fan performance for airflow, pressure, power, air density, rotation speed, and efficiency. Rate performance according to AMCA 210, "Laboratory Methods of Testing Fans for Aerodynamic Performance Rating."
- C. Water Coils: Factory tested to 300 psig according to ARI 410 and ASHRAE 33.
- D. Steam Coils: Factory tested to 300 psig and to 200 psig underwater according to ARI 410 and ASHRAE 33.
- E. Refrigerant Coils: Factory tested to 450 psig according to ARI 410 and ASHRAE 33.

## PART 3 - EXECUTION

### 3.1 EXAMINATION

- A. Examine areas and conditions, with Installer present, for compliance with requirements for installation tolerances and other conditions affecting performance of the Work.
- B. Examine casing insulation materials and filter media before air-handling unit installation. Reject insulation materials and filter media that are wet, moisture damaged, or mold damaged.
- C. Examine roughing-in for steam, hydronic, and condensate drainage piping systems and electrical services to verify actual locations of connections before installation.
- D. Proceed with installation only after unsatisfactory conditions have been corrected.

### 3.2 INSTALLATION

- A. Equipment Mounting:
  1. Install air-handling units on cast-in-place concrete equipment bases. Comply with requirements for equipment bases and foundations specified in Section 033053 "Miscellaneous Cast-in-Place Concrete."
  2. Comply with requirements for vibration isolation and seismic control devices specified in Section 230548 "Vibration and Seismic Controls for HVAC."

3. Comply with requirements for vibration isolation devices specified in Section 230548.13 "Vibration Controls for HVAC."
  - B. Suspended Units: Suspend and brace units from structural-steel support frame using threaded steel rods and spring hangers. Comply with requirements for vibration isolation devices specified in Section 230548.13 "Vibration Controls for HVAC."
  - C. Arrange installation of units to provide access space around air-handling units for service and maintenance.
  - D. Do not operate fan system until filters (temporary or permanent) are in place. Replace temporary filters used during construction and testing, with new, clean filters.
  - E. Install filter-gage, static-pressure taps upstream and downstream of filters. Mount filter gages on outside of filter housing or filter plenum in accessible position. Provide filter gages on filter banks, installed with separate static-pressure taps upstream and downstream of filters.

### 3.3 CONNECTIONS

- A. Comply with requirements for piping specified in other Sections. Drawings indicate general arrangement of piping, fittings, and specialties.
- B. Install piping adjacent to air-handling unit to allow service and maintenance.
- C. Connect piping to air-handling units mounted on vibration isolators with flexible connectors.
- D. Connect condensate drain pans using NPS 1-1/4, ASTM B 88, Type M copper tubing. Extend to nearest equipment or floor drain. Construct deep trap at connection to drain pan and install cleanouts at changes in direction.
- E. Hot- and Chilled-Water Piping: Comply with applicable requirements in Section 232113 "Hydronic Piping" and Section 232116 Hydronic Piping Specialties." Install shutoff valve and union or flange at each coil supply connection. Install balancing valve and union or flange at each coil return connection.
- F. Steam and Condensate Piping: Comply with applicable requirements in Section 232213 "Steam and Condensate Heating Piping" and Section 232216 Steam and Condensate Piping Specialties." Install shutoff valve at steam supply connections, float and thermostatic trap, and union or flange at each coil return connection. Install gate valve and inlet strainer at supply connection of dry steam humidifiers, and inverted bucket steam trap to condensate return connection.
- G. Refrigerant Piping: Comply with applicable requirements in Section 232300 "Refrigerant Piping." Install shutoff valve and union or flange at each supply and return connection.
- H. Connect duct to air-handling units with flexible connections. Comply with requirements in Section 233300 "Air Duct Accessories."

### 3.4 FIELD QUALITY CONTROL

- A. Manufacturer's Field Service: Engage a factory-authorized service representative to inspect, test, and adjust components, assemblies, and equipment installations, including connections.
- B. Perform tests and inspections.
  - 1. Manufacturer's Field Service: Engage a factory-authorized service representative to inspect components, assemblies, and equipment installations, including connections, and to assist in testing.
- C. Tests and Inspections:
  - 1. Leak Test: After installation, fill water and steam coils with water, and test coils and connections for leaks.
  - 2. Charge refrigerant coils with refrigerant and test for leaks.
  - 3. Fan Operational Test: After electrical circuitry has been energized, start units to confirm proper motor rotation and unit operation.
  - 4. Automatic-Roll-Filter Operational Test: Operate filters to demonstrate compliance with requirements. Test for leakage of unfiltered air while system is operating.
  - 5. HEPA-Filter Operational Test: Pressurize housing to a minimum of 3-inch wg or to designed operating pressure, whichever is higher; test housing joints, door seals, and sealing edges of filter with soapy water to check for air leaks.
  - 6. HEPA-Filter Operational Test: Pressurize housing to a minimum of 3-inch wg or to designed operating pressure, whichever is higher; test housing joints, door seals, and sealing edges of filter for air leaks according to ASME N510, pressure-decay method.
  - 7. Test and adjust controls and safeties. Replace damaged and malfunctioning controls and equipment.
- D. Air-handling unit or components will be considered defective if unit or components do not pass tests and inspections.
- E. Prepare test and inspection reports.

### 3.5 STARTUP SERVICE

- A. Engage a factory-authorized service representative to perform startup service.
  - 1. Complete installation and startup checks according to manufacturer's written instructions.
  - 2. Verify that shipping, blocking, and bracing are removed.
  - 3. Verify that unit is secure on mountings and supporting devices and that connections to piping, ducts, and electrical systems are complete. Verify that proper thermal-overload protection is installed in motors, controllers, and switches.
  - 4. Verify proper motor rotation direction, free fan wheel rotation, and smooth bearing operations. Reconnect fan drive system, align belts, and install belt guards.
  - 5. Verify that bearings, pulleys, belts, and other moving parts are lubricated with factory-recommended lubricants.
  - 6. Verify that zone dampers fully open and close for each zone.
  - 7. Verify that face-and-bypass dampers provide full face flow.

8. Verify that outdoor- and return-air mixing dampers open and close, and maintain minimum outdoor-air setting.
9. Comb coil fins for parallel orientation.
10. Verify that proper thermal-overload protection is installed for electric coils.
11. Install new, clean filters.
12. Verify that manual and automatic volume control and fire and smoke dampers in connected duct systems are in fully open position.

B. Starting procedures for air-handling units include the following:

1. Energize motor; verify proper operation of motor, drive system, and fan wheel. Adjust fan to indicated rpm. Replace fan and motor pulleys as required to achieve design conditions.
2. Measure and record motor electrical values for voltage and amperage.
3. Manually operate dampers from fully closed to fully open position and record fan performance.

### 3.6 ADJUSTING

- A. Adjust damper linkages for proper damper operation.
- B. Comply with requirements in Section 230593 "Testing, Adjusting, and Balancing for HVAC" for air-handling system testing, adjusting, and balancing.

### 3.7 CLEANING

- A. After completing system installation and testing, adjusting, and balancing air-handling unit and air-distribution systems and after completing startup service, clean air-handling units internally to remove foreign material and construction dirt and dust. Clean fan wheels, cabinets, dampers, coils, and filter housings, and install new, clean filters.

### 3.8 DEMONSTRATION

- A. Engage a factory-authorized service representative to train Owner's maintenance personnel to adjust, operate, and maintain air-handling units.

END OF SECTION 237313

## SECTION 230713 - DUCT INSULATION

## PART 1 - GENERAL

## 1.1 RELATED DOCUMENTS

- A. Drawings and general provisions of the Contract, including General and Supplementary Conditions and Division 01 Specification Sections, apply to this Section.

## 1.2 SUMMARY

- A. Section includes insulating the following duct services:
  - 1. Indoor, concealed supply and outdoor air.
  - 2. Indoor, exposed supply and outdoor air.
  - 3. Indoor, concealed return located in unconditioned space.
  - 4. Indoor, exposed return located in unconditioned space.
- B. Related Sections:
  - 1. Section 230719 "HVAC Piping Insulation."
  - 2. Section 233113 "Metal Ducts" for duct liners.

## 1.3 ACTION SUBMITTALS

- A. Product Data: For each type of product indicated. Include thermal conductivity, water-vapor permeance thickness, and jackets (both factory- and field-applied if any).
- B. Shop Drawings: Include plans, elevations, sections, details, and attachments to other work.
  - 1. Detail application of protective shields, saddles, and inserts at hangers for each type of insulation and hanger.
  - 2. Detail insulation application at elbows, fittings, dampers, specialties and flanges for each type of insulation.
  - 3. Detail application of field-applied jackets.
  - 4. Detail application at linkages of control devices.

## 1.4 QUALITY ASSURANCE

- A. Surface-Burning Characteristics: For insulation and related materials, as determined by testing identical products according to ASTM E 84, by a testing agency acceptable to authorities having jurisdiction. Factory label insulation and jacket materials and adhesive, mastic, tapes, and cement material containers, with appropriate markings of applicable testing agency.



1. Insulation Installed Indoors: Flame-spread index of 25 or less, and smoke-developed index of 50 or less.
2. Insulation Installed Outdoors: Flame-spread index of 75 or less, and smoke-developed index of 150 or less.

#### 1.5 DELIVERY, STORAGE, AND HANDLING

- A. Packaging: Insulation material containers shall be marked by manufacturer with appropriate ASTM standard designation, type and grade, and maximum use temperature.

#### 1.6 COORDINATION

- A. Coordinate sizes and locations of supports, hangers, and insulation shields specified in Section 230529 "Hangers and Supports for HVAC Piping and Equipment."
- B. Coordinate clearance requirements with duct Installer for duct insulation application. Before preparing ductwork Shop Drawings, establish and maintain clearance requirements for installation of insulation and field-applied jackets and finishes and for space required for maintenance.

#### 1.7 SCHEDULING

- A. Schedule insulation application after pressure testing systems. Insulation application may begin on segments that have satisfactory test results.
- B. Complete installation and concealment of plastic materials as rapidly as possible in each area of construction.

### PART 2 - PRODUCTS

#### 2.1 INSULATION MATERIALS

- A. Comply with requirements in "Duct Insulation Schedule, General," "Indoor Duct and Plenum Insulation Schedule," articles for where insulating materials shall be applied.
- B. Products shall not contain asbestos, lead, mercury, or mercury compounds.
- C. Foam insulation materials shall not use CFC or HCFC blowing agents in the manufacturing process.
- D. Flexible Elastomeric Insulation: Closed-cell, sponge- or expanded-rubber materials. Comply with ASTM C 534, Type II for sheet materials.
  1. Products: Subject to compliance with requirements, available products that may be incorporated into the Work include, but are not limited to, the following:

- a. Aeroflex USA, Inc.; Aerocel.
  - b. Armacell LLC; AP Armaflex.
  - c. K-Flex USA; Insul-Sheet, K-Flex Gray Duct Liner, and K-FLEX LS.
- E. Mineral-Fiber Blanket Insulation: Mineral or glass fibers bonded with a thermosetting resin. Comply with ASTM C 553, Type II and ASTM C 1290, Type III with factory-applied FSK jacket Type III with factory-applied FSP jacket. Factory-applied jacket requirements are specified in "Factory-Applied Jackets" Article.
1. Products: Subject to compliance with requirements, provide one of the following available products:
    - a. CertainTeed Corp.; SoftTouch Duct Wrap.
    - b. Johns Manville; Microlite.
    - c. Knauf Insulation; Friendly Feel Duct Wrap.
    - d. Owens Corning; SOFTR All-Service Duct Wrap.
- F. Mineral-Fiber Board Insulation: Mineral or glass fibers bonded with a thermosetting resin. Comply with ASTM C 612, Type IA or Type IB. For duct and plenum applications, provide insulation with factory-applied FSK jacket. Factory-applied jacket requirements are specified in "Factory-Applied Jackets" Article.
1. Products: Subject to compliance with requirements, provide one of the following available products:
    - a. CertainTeed Corp.; Commercial Board.
    - b. Johns Manville; 800 Series Spin-Glas.
    - c. Knauf Insulation; Insulation Board.
    - d. Owens Corning; Fiberglas 700 Series.
- G. Mineral-Fiber, Pipe and Tank Insulation: Mineral or glass fibers bonded with a thermosetting resin. Semirigid board material with factory-applied FSK jacket complying with ASTM C 1393, Type II or Type IIIA Category 2, or with properties similar to ASTM C 612, Type IB. Nominal density is 2.5 lb/cu. ft. or more. Thermal conductivity (k-value) at 100 deg F is 0.29 Btu x in./h x sq. ft. x deg F or less.
1. Products: Subject to compliance with requirements, provide one of the following available products:
    - a. CertainTeed Corp.; CrimpWrap.
    - b. Johns Manville; MicroFlex.
    - c. Knauf Insulation; Pipe and Tank Insulation.
    - d. Owens Corning; Fiberglas Pipe and Tank Insulation.

## 2.2 FIRE-RATED INSULATION SYSTEMS

- A. Fire-Rated Board: Structural-grade, press-molded, xonolite calcium silicate, fireproofing board suitable for operating temperatures up to 1700 deg F. Comply with ASTM C 656, Type II, Grade 6. Tested and certified to provide a 2-hour fire rating by an NRTL acceptable to authorities having jurisdiction.

1. Products: Subject to compliance with requirements, provide one of the following available products:
  - a. Johns Manville; Super Firetemp M.

## 2.3 ADHESIVES

### A. Flexible Elastomeric and Polyolefin Adhesive: Comply with MIL-A-24179A, Type II, Class I.

1. Products: Subject to compliance with requirements, provide one of the following available products:
  - a. Aeroflex USA, Inc.; Aeroseal.
  - b. Armacell LLC; Armaflex 520 Adhesive.
  - c. Foster Brand, Specialty Construction Brands, Inc., a business of H. B. Fuller Company; 85-75.K-Flex USA; R-373 Contact Adhesive.
2. For indoor applications, adhesive shall have a VOC content of 50 g/L or less when calculated according to 40 CFR 59, Subpart D (EPA Method 24).

### B. Mineral-Fiber Adhesive: Comply with MIL-A-3316C, Class 2, Grade A.

1. Products: Subject to compliance with requirements, provide one of the following available products:
  - a. Childers Brand, Specialty Construction Brands, Inc., a business of H. B. Fuller Company; CP-127.Eagle Bridges - Marathon Industries; 225.
  - b. Foster Brand, Specialty Construction Brands, Inc.
2. For indoor applications, adhesive shall have a VOC content of 80 g/L or less when calculated according to 40 CFR 59, Subpart D (EPA Method 24).

### C. ASJ Adhesive, and FSK Jacket Adhesive: Comply with MIL-A-3316C, Class 2, Grade A for bonding insulation jacket lap seams and joints.

1. Products: Subject to compliance with requirements, provide one of the following available products:
  - a. Childers Brand, Specialty Construction Brands, Inc., a business of H. B. Fuller Company; CP-82.
  - b. Eagle Bridges - Marathon Industries; 225.
  - c. Foster Brand, Specialty Construction Brands, Inc.
2. For indoor applications, adhesive shall have a VOC content of 50 g/L or less when calculated according to 40 CFR 59, Subpart D (EPA Method 24).

## 2.4 MASTICS

- A. Materials shall be compatible with insulation materials, jackets, and substrates; comply with MIL-PRF-19565C, Type II.

- B. Vapor-Barrier Mastic: Water based; suitable for indoor use on below ambient services.
1. Products: Subject to compliance with requirements, provide one of the following available products:
    - a. Foster Brand, Specialty Construction Brands, Inc., a business of H. B. Fuller Company; 30-80/30-90.
    - b. Vimasco Corporation; 749.
  2. Water-Vapor Permeance: ASTM E 96/E 96M, Procedure B, 0.013 perm at 43-mil dry film thickness.
  3. Service Temperature Range: Minus 20 to plus 180 deg F.
  4. Solids Content: ASTM D 1644, 58 percent by volume and 70 percent by weight.
  5. Color: White.

## 2.5 LAGGING ADHESIVES

- A. Description: Comply with MIL-A-3316C, Class I, Grade A and shall be compatible with insulation materials, jackets, and substrates.
1. For indoor applications, use lagging adhesives that have a VOC content of 50 g/L or less when calculated according to 40 CFR 59, Subpart D (EPA Method 24).
  2. Products: Subject to compliance with requirements, provide one of the following available products :
    - a. Childers Brand, Specialty Construction Brands, Inc., a business of H. B. Fuller Company; CP-50 AHV2.Foster Brand, Specialty Construction Brands, Inc., a business of H. B. Fuller Company; 30-36.
    - b. Vimasco Corporation; 713 and 714.
  3. Fire-resistant, water-based lagging adhesive and coating for use indoors to adhere fire-resistant lagging cloths over duct insulation.
  4. Service Temperature Range: 0 to plus 180 deg F.
  5. Color: White.

## 2.6 SEALANTS

- A. FSK and Metal Jacket Flashing Sealants:
1. Products: Subject to compliance with requirements, provide one of the following available products:
    - a. Childers Brand, Specialty Construction Brands, Inc.
    - b. Foster Brand, Specialty Construction Brands, Inc.
    - c. Mon-Eco Industries, Inc.; 44-05.
  2. Materials shall be compatible with insulation materials, jackets, and substrates.
  3. Fire- and water-resistant, flexible, elastomeric sealant.
  4. Service Temperature Range: Minus 40 to plus 250 deg F.
  5. Color: Aluminum.

6. For indoor applications, sealants shall have a VOC content of 420 g/L or less when calculated according to 40 CFR 59, Subpart D (EPA Method 24).

B. ASJ Flashing Sealants:

1. Products: Subject to compliance with requirements, provide one of the following available products:
  - a. Childers Brand, Specialty Construction Brands, Inc., a business of H. B. Fuller Company; CP-76.
2. Materials shall be compatible with insulation materials, jackets, and substrates.
3. Fire- and water-resistant, flexible, elastomeric sealant.
4. Service Temperature Range: Minus 40 to plus 250 deg F.
5. Color: White.
6. For indoor applications, sealants shall have a VOC content of 420 g/L or less when calculated according to 40 CFR 59, Subpart D (EPA Method 24).

## 2.7 FACTORY-APPLIED JACKETS

- A. Insulation system schedules indicate factory-applied jackets on various applications. When factory-applied jackets are indicated, comply with the following:
1. ASJ: White, kraft-paper, fiberglass-reinforced scrim with aluminum-foil backing; complying with ASTM C 1136, Type I.
  2. ASJ-SSL: ASJ with self-sealing, pressure-sensitive, acrylic-based adhesive covered by a removable protective strip; complying with ASTM C 1136, Type I.
  3. FSK Jacket: Aluminum-foil, fiberglass-reinforced scrim with kraft-paper backing; complying with ASTM C 1136, Type II.
  4. FSP Jacket: Aluminum-foil, fiberglass-reinforced scrim with polyethylene backing; complying with ASTM C 1136, Type II.

## 2.8 FIELD-APPLIED FABRIC-REINFORCING MESH

- A. Woven Glass-Fiber Fabric: Approximately 6 oz./sq. yd. with a thread count of 5 strands by 5 strands/sq. in. for covering ducts.
1. Products: Subject to compliance with requirements, provide one of the following available products:
    - a. Childers Brand, Specialty Construction Brands, Inc., a business of H. B. Fuller Company; Chil-Glas No. 5.
- B. Woven Polyester Fabric: Approximately 1 oz./sq. yd. with a thread count of 10 strands by 10 strands/sq. in., in a Leno weave, for ducts.
1. Products: Subject to compliance with requirements, provide one of the following available products:

- a. Foster Brand, Specialty Construction Brands, Inc., a business of H. B. Fuller Company; Mast-A-Fab.
- b. Vimasco Corporation; Elastafab 894.

C. Metal Jacket:

1. Products: Subject to compliance with requirements, provide one of the following available products:
  - a. Childers Brand, Specialty Construction Brands, Inc., a business of H. B. Fuller Company; Metal Jacketing Systems.
  - b. ITW Insulation Systems; Aluminum and Stainless Steel Jacketing.
  - c. RPR Products, Inc.; Insul-Mate.
2. Aluminum Jacket: Comply with ASTM B 209, Alloy 3003, 3005, 3105, or 5005, Temper H-14.
  - a. Sheet and roll stock ready for shop or field sizing or Factory cut and rolled to size.
  - b. Finish and thickness are indicated in field-applied jacket schedules.
  - c. Moisture Barrier for Indoor Applications: 3-mil- thick, heat-bonded polyethylene and kraft paper.

2.9 TAPES

- A. ASJ Tape: White vapor-retarder tape matching factory-applied jacket with acrylic adhesive, complying with ASTM C 1136.
1. Products: Subject to compliance with requirements, provide one of the following available products :
    - a. ABI, Ideal Tape Division; 428 AWF ASJ.
    - b. Avery Dennison Corporation, Specialty Tapes Division; Fasson 0836.
    - c. Compac Corporation; 104 and 105.
    - d. Venture Tape; 1540 CW Plus, 1542 CW Plus, and 1542 CW Plus/SQ.
  2. Width: 3 inches.
  3. Thickness: 11.5 mils.
  4. Adhesion: 90 ounces force/inch in width.
  5. Elongation: 2 percent.
  6. Tensile Strength: 40 lbf/inch in width.
  7. ASJ Tape Disks and Squares: Precut disks or squares of ASJ tape.
- B. FSK Tape: Foil-face, vapor-retarder tape matching factory-applied jacket with acrylic adhesive; complying with ASTM C 1136.
1. Products: Subject to compliance with requirements, provide one of the following available products:
    - a. ABI, Ideal Tape Division; 491 AWF FSK.
    - b. Avery Dennison Corporation, Specialty Tapes Division; Fasson 0827.
    - c. Compac Corporation; 110 and 111.

- d. Venture Tape; 1525 CW NT, 1528 CW, and 1528 CW/SQ.
  2. Width: 3 inches.
  3. Thickness: 6.5 mils.
  4. Adhesion: 90 ounces force/inch in width.
  5. Elongation: 2 percent.
  6. Tensile Strength: 40 lbf/inch in width.
  7. FSK Tape Disks and Squares: Precut disks or squares of FSK tape.
- C. Aluminum-Foil Tape: Vapor-retarder tape with acrylic adhesive.
  1. Products: Subject to compliance with requirements, provide one of the following available products:
    - a. ABI, Ideal Tape Division; 488 AWF.
    - b. Avery Dennison Corporation, Specialty Tapes Division; Fasson 0800.
    - c. Compac Corporation; 120.
    - d. Venture Tape; 3520 CW.
  2. Width: 2 inches.
  3. Thickness: 3.7 mils.
  4. Adhesion: 100 ounces force/inch in width.
  5. Elongation: 5 percent.
  6. Tensile Strength: 34 lbf/inch in width.

## 2.10 SECUREMENTS

- A. Bands:
  1. Products: Subject to compliance with requirements, provide one of the following available products:
    - a. ITW Insulation Systems; Gerrard Strapping and Seals.
    - b. RPR Products, Inc.; Insul-Mate Strapping, Seals, and Springs.
  2. Aluminum: ASTM B 209, Alloy 3003, 3005, 3105, or 5005; Temper H-14, 0.020 inch thick, 3/4 inch wide with wing seal or closed seal.

## PART 3 - EXECUTION

### 3.1 EXAMINATION

- A. Examine substrates and conditions for compliance with requirements for installation tolerances and other conditions affecting performance of insulation application.
  1. Verify that systems to be insulated have been tested and are free of defects.
  2. Verify that surfaces to be insulated are clean and dry.
- B. Proceed with installation only after unsatisfactory conditions have been corrected.

### 3.2 PREPARATION

- A. Surface Preparation: Clean and dry surfaces to receive insulation. Remove materials that will adversely affect insulation application.

### 3.3 GENERAL INSTALLATION REQUIREMENTS

- A. Install insulation materials, accessories, and finishes with smooth, straight, and even surfaces; free of voids throughout the length of ducts and fittings.
- B. Install insulation materials, vapor barriers or retarders, jackets, and thicknesses required for each item of duct system as specified in insulation system schedules.
- C. Install accessories compatible with insulation materials and suitable for the service. Install accessories that do not corrode, soften, or otherwise attack insulation or jacket in either wet or dry state.
- D. Install insulation with longitudinal seams at top and bottom of horizontal runs.
- E. Install multiple layers of insulation with longitudinal and end seams staggered.
- F. Keep insulation materials dry during application and finishing.
- G. Install insulation with tight longitudinal seams and end joints. Bond seams and joints with adhesive recommended by insulation material manufacturer.
- H. Install insulation with least number of joints practical.
- I. Where vapor barrier is indicated, seal joints, seams, and penetrations in insulation at hangers, supports, anchors, and other projections with vapor-barrier mastic.
  - 1. Install insulation continuously through hangers and around anchor attachments.
  - 2. For insulation application where vapor barriers are indicated, extend insulation on anchor legs from point of attachment to supported item to point of attachment to structure. Taper and seal ends at attachment to structure with vapor-barrier mastic.
  - 3. Install insert materials and install insulation to tightly join the insert. Seal insulation to insulation inserts with adhesive or sealing compound recommended by insulation material manufacturer.
- J. Apply adhesives, mastics, and sealants at manufacturer's recommended coverage rate and wet and dry film thicknesses.
- K. Install insulation with factory-applied jackets as follows:
  - 1. Draw jacket tight and smooth.
  - 2. Cover circumferential joints with 3-inch- wide strips, of same material as insulation jacket. Secure strips with adhesive and outward clinching staples along both edges of strip, spaced 4 inches o.c.
  - 3. Overlap jacket longitudinal seams at least 1-1/2 inches. Clean and dry surface to receive self-sealing lap. Staple laps with outward clinching staples along edge at 2 inches o.c.



- a. For below ambient services, apply vapor-barrier mastic over staples.
- 4. Cover joints and seams with tape, according to insulation material manufacturer's written instructions, to maintain vapor seal.
- 5. Where vapor barriers are indicated, apply vapor-barrier mastic on seams and joints and at ends adjacent to duct flanges and fittings.
- L. Cut insulation in a manner to avoid compressing insulation more than 75 percent of its nominal thickness.
- M. Finish installation with systems at operating conditions. Repair joint separations and cracking due to thermal movement.
- N. Repair damaged insulation facings by applying same facing material over damaged areas. Extend patches at least 4 inches beyond damaged areas. Adhere, staple, and seal patches similar to butt joints.

### 3.4 PENETRATIONS

- A. Insulation Installation at Roof Penetrations: Install insulation continuously through roof penetrations.
  - 1. Seal penetrations with flashing sealant.
  - 2. For applications requiring only indoor insulation, terminate insulation above roof surface and seal with joint sealant. For applications requiring indoor and outdoor insulation, install insulation for outdoor applications tightly joined to indoor insulation ends. Seal joint with joint sealant.
  - 3. Extend jacket of outdoor insulation outside roof flashing at least 2 inches below top of roof flashing.
  - 4. Seal jacket to roof flashing with flashing sealant.
- B. Insulation Installation at Interior Wall and Partition Penetrations (That Are Not Fire Rated): Install insulation continuously through walls and partitions.
- C. Insulation Installation at Fire-Rated Wall and Partition Penetrations: Terminate insulation at fire damper sleeves for fire-rated wall and partition penetrations. Externally insulate damper sleeves to match adjacent insulation and overlap duct insulation at least 2 inches.
  - 1. Comply with requirements in Section 078413 "Penetration Firestopping"irestopping and fire-resistive joint sealers.
- D. Insulation Installation at Floor Penetrations:
  - 1. Duct: For penetrations through fire-rated assemblies, terminate insulation at fire damper sleeves and externally insulate damper sleeve beyond floor to match adjacent duct insulation. Overlap damper sleeve and duct insulation at least 2 inches.
  - 2. Seal penetrations through fire-rated assemblies. Comply with requirements in Section 078413 "Penetration Firestopping."

### 3.5 INSTALLATION OF MINERAL-FIBER INSULATION

- A. Blanket Insulation Installation on Ducts and Plenums: Secure with adhesive and insulation pins.
1. Apply adhesives according to manufacturer's recommended coverage rates per unit area, for 100 percent coverage of duct and plenum surfaces.
  2. Apply adhesive to entire circumference of ducts and to all surfaces of fittings and transitions.
  3. Install either capacitor-discharge-weld pins and speed washers or cupped-head, capacitor-discharge-weld pins on sides and bottom of horizontal ducts and sides of vertical ducts as follows:
    - a. On duct sides with dimensions 18 inches and smaller, place pins along longitudinal centerline of duct. Space 3 inches maximum from insulation end joints, and 16 inches o.c.
    - b. On duct sides with dimensions larger than 18 inches, place pins 16 inches o.c. each way, and 3 inches maximum from insulation joints. Install additional pins to hold insulation tightly against surface at cross bracing.
    - c. Pins may be omitted from top surface of horizontal, rectangular ducts and plenums.
    - d. Do not overcompress insulation during installation.
    - e. Impale insulation over pins and attach speed washers.
    - f. Cut excess portion of pins extending beyond speed washers or bend parallel with insulation surface. Cover exposed pins and washers with tape matching insulation facing.
  4. For ducts and plenums with surface temperatures below ambient, install a continuous unbroken vapor barrier. Create a facing lap for longitudinal seams and end joints with insulation by removing 2 inches from one edge and one end of insulation segment. Secure laps to adjacent insulation section with 1/2-inch outward-clinching staples, 1 inch o.c. Install vapor barrier consisting of factory- or field-applied jacket, adhesive, vapor-barrier mastic, and sealant at joints, seams, and protrusions.
    - a. Repair punctures, tears, and penetrations with tape or mastic to maintain vapor-barrier seal.
    - b. Install vapor stops for ductwork and plenums operating below 50 deg F at 18-foot intervals. Vapor stops shall consist of vapor-barrier mastic applied in a Z-shaped pattern over insulation face, along butt end of insulation, and over the surface. Cover insulation face and surface to be insulated a width equal to two times the insulation thickness, but not less than 3 inches.
  5. Overlap unfaced blankets a minimum of 2 inches on longitudinal seams and end joints. At end joints, secure with steel bands spaced a maximum of 18 inches o.c.
  6. Install insulation on rectangular duct elbows and transitions with a full insulation section for each surface. Install insulation on round and flat-oval duct elbows with individually mitered gores cut to fit the elbow.
  7. Insulate duct stiffeners, hangers, and flanges that protrude beyond insulation surface with 6-inch- wide strips of same material used to insulate duct. Secure on alternating sides of stiffener, hanger, and flange with pins spaced 6 inches o.c.
- B. Board Insulation Installation on Ducts and Plenums: Secure with adhesive and insulation pins.

1. Apply adhesives according to manufacturer's recommended coverage rates per unit area, for 100 percent coverage of duct and plenum surfaces.
2. Apply adhesive to entire circumference of ducts and to all surfaces of fittings and transitions.
3. Install either capacitor-discharge-weld pins and speed washers or cupped-head, capacitor-discharge-weld pins on sides and bottom of horizontal ducts and sides of vertical ducts as follows:
  - a. On duct sides with dimensions 18 inches and smaller, place pins along longitudinal centerline of duct. Space 3 inches maximum from insulation end joints, and 16 inches o.c.
  - b. On duct sides with dimensions larger than 18 inches, space pins 16 inches o.c. each way, and 3 inches maximum from insulation joints. Install additional pins to hold insulation tightly against surface at cross bracing.
  - c. Pins may be omitted from top surface of horizontal, rectangular ducts and plenums.
  - d. Do not overcompress insulation during installation.
  - e. Cut excess portion of pins extending beyond speed washers or bend parallel with insulation surface. Cover exposed pins and washers with tape matching insulation facing.
4. For ducts and plenums with surface temperatures below ambient, install a continuous unbroken vapor barrier. Create a facing lap for longitudinal seams and end joints with insulation by removing 2 inches from one edge and one end of insulation segment. Secure laps to adjacent insulation section with 1/2-inch outward-clinching staples, 1 inch o.c. Install vapor barrier consisting of factory- or field-applied jacket, adhesive, vapor-barrier mastic, and sealant at joints, seams, and protrusions.
  - a. Repair punctures, tears, and penetrations with tape or mastic to maintain vapor-barrier seal.
  - b. Install vapor stops for ductwork and plenums operating below 50 deg F at 18-foot intervals. Vapor stops shall consist of vapor-barrier mastic applied in a Z-shaped pattern over insulation face, along butt end of insulation, and over the surface. Cover insulation face and surface to be insulated a width equal to two times the insulation thickness, but not less than 3 inches.
5. Install insulation on rectangular duct elbows and transitions with a full insulation section for each surface. Groove and score insulation to fit as closely as possible to outside and inside radius of elbows. Install insulation on round and flat-oval duct elbows with individually mitered gores cut to fit the elbow.
6. Insulate duct stiffeners, hangers, and flanges that protrude beyond insulation surface with 6-inch- wide strips of same material used to insulate duct. Secure on alternating sides of stiffener, hanger, and flange with pins spaced 6 inches o.c.

### 3.6 FIELD-APPLIED JACKET INSTALLATION

- A. Where glass-cloth jackets are indicated, install directly over bare insulation or insulation with factory-applied jackets.
  1. Draw jacket smooth and tight to surface with 2-inch overlap at seams and joints.
  2. Embed glass cloth between two 0.062-inch- thick coats of lagging adhesive.

3. Completely encapsulate insulation with coating, leaving no exposed insulation.

- B. Where FSK jackets are indicated, install as follows:

1. Draw jacket material smooth and tight.
2. Install lap or joint strips with same material as jacket.
3. Secure jacket to insulation with manufacturer's recommended adhesive.
4. Install jacket with 1-1/2-inch laps at longitudinal seams and 3-inch- wide joint strips at end joints.
5. Seal openings, punctures, and breaks in vapor-retarder jackets and exposed insulation with vapor-barrier mastic.

- C. Where metal jackets are indicated, install with 2-inch overlap at longitudinal seams and end joints. Overlap longitudinal seams arranged to shed water. Seal end joints with weatherproof sealant recommended by insulation manufacturer. Secure jacket with stainless-steel bands 12 inches o.c. and at end joints.

### 3.7 FIRE-RATED INSULATION SYSTEM INSTALLATION

- A. Where fire-rated insulation system is indicated, secure system to ducts and duct hangers and supports to maintain a continuous fire rating.
- B. Insulate duct access panels and doors to achieve same fire rating as duct.
- C. Install firestopping at penetrations through fire-rated assemblies. Fire-stop systems are specified in Section 078413 "Penetration Firestopping."

### 3.8 FINISHES

- A. Insulation with ASJ, Glass-Cloth, or Other Paintable Jacket Material: Paint jacket with paint system identified below and as specified in Section 099123 "Interior Painting."
1. Flat Acrylic Finish: Two finish coats over a primer that is compatible with jacket material and finish coat paint. Add fungicidal agent to render fabric mildew proof.
    - a. Finish Coat Material: Interior, flat, latex-emulsion size.
- B. Color: Final color as selected by Architect. Vary first and second coats to allow visual inspection of the completed Work.
- C. Do not field paint aluminum or stainless-steel jackets.

### 3.9 FIELD QUALITY CONTROL

- A. Perform tests and inspections.
- B. Tests and Inspections:

1. Inspect ductwork, randomly selected by Architect, by removing field-applied jacket and insulation in layers in reverse order of their installation. Extent of inspection shall be limited to one location(s) for each duct system defined in the "Duct Insulation Schedule, General" Article.

- C. All insulation applications will be considered defective Work if sample inspection reveals noncompliance with requirements.

### 3.10 DUCT INSULATION SCHEDULE, GENERAL

A. Plenums and Ducts Requiring Insulation:

1. Indoor, concealed supply and outdoor air.
2. Indoor, exposed supply and outdoor air.
3. Indoor, concealed return located in unconditioned space.
4. Indoor, exposed return located in unconditioned space.

B. Items Not Insulated:

1. Metal ducts and plenums with duct liner of sufficient thickness to comply with energy code and ASHRAE/IESNA 90.1.
2. Factory-insulated flexible ducts.
3. Factory-insulated plenums and casings.
4. Flexible connectors.
5. Vibration-control devices.
6. Factory-insulated access panels and doors.

### 3.11 INDOOR DUCT AND PLENUM INSULATION SCHEDULE

A. Concealed, round, supply return and outside-air duct insulation shall be the following:

1. Mineral-Fiber blanket: 2 inches thick and 1.5-lb/cu. ft. nominal density.

B. Concealed, rectangular, supply-return and outside air duct insulation shall be the following:

1. Mineral-Fiber Blanket: 2 inches thick and 1.5-lb/cu. ft. nominal density.

C. Concealed, supply-air plenum insulation shall be the following:

1. Mineral-Fiber Blanket: 2 inches thick and 1.5-lb/cu. ft. nominal density.

D. Exposed, round supply-return and outdoor air duct insulation shall be the following:

1. Mineral-Fiber Pipe and Tank: 2 inches thick.
2. Field applied metal jacket.

E. Exposed, rectangular, supply-return, outside air duct and plenum insulation shall be the following:

1. Mineral-Fiber Board: 2 inches thick and 6-lb/cu. ft. nominal density.

3.12 INDOOR, FIELD-APPLIED JACKET SCHEDULE

- A. Install jacket over insulation material. For insulation with factory-applied jacket, install the field-applied jacket over the factory-applied jacket.
- B. Ducts and Plenums, Exposed:
  - 1. Painted Aluminum, Smooth: 0.024 inch thick.

END OF SECTION 230713

Furniture Schedule

Type Mark	Manufacturer	Model	Description	Count
<b>00 LEVEL C</b>				
B-1	Gaylord	1434-1	BULLETIN BOARD	3
CH-2	KI	ILST.30-CH-CD-SG-NP	30" High Stool with Chrome Base and Dark Grey Seat	36
CH-3	KI	ILST.24-CH-CD-SG-NP	24" High Stool with Chrome Base and Dark Grey Seat	52
CH-4	Allseating	16030-PY-H	Dove Lab Chair- Standard Height with Hard Surface Casters	65
CH-5	KI	M16TRP-CH-PWG-XX-S	Matrix Tablet Armchair with Poly Seat and Back, Right Handed, Hard Floor Casters	20
D-1	KI	TR3060/P-74P-R-YCG	True Desking System with Partial Modesty Panel and Right Transitional- Balance Overhead Storage, Privacy Screen and Center Grommet	4
D-2	KI	TR3060/P-74P-B-YCG	True Desking System with Partial Modesty Panel and Both Transitional- Balance Overhead Storage, Privacy Screen and Center Grommet	3
D-2.1	KI		Same Specification as D-2 with the Addition of Activ8 Power Management System	1
D-3	KI	TR3060/P-74P-L-YCG	True Desking System with Partial Modesty Panel and Left Transitional- Balance Overhead Storage, Privacy Screen and Center Grommet	3
D-3.1	KI		Same Specification as D-3 with the addition of the Activ8 Power Management System	1
T-3	KI	Special- Drawing No. M9-395344-100	Genesis Desk 30" x 48" w/ Foldaway Monitor Arm	20
T-4	KI, Inc.	HULN2472-ME-XX-XX-CH-4CB	Hurry Up Table with 4 Black Casters- No Power	4
T-5	KI, Inc.	HULN2460-ME-XX-XX-CH-4CB	Hurry Up Table with 4 Black Casters- No Power	5
T-6	KI, Inc.	HULN2448-74P-XX-XX-CH-4MB	Hurry Up Table with 2 Black Casters and 2 Black Glides- One Grommet	1
T-7	KI, Inc.	HULN2460-74P-XX-XX-CH-4CB	Hurry Up Table with 4 Black Casters and 74P Edge- with Grommet	2
<b>02 PLAZA LEVEL A</b>				
CH-1	KI	MX-NS-CH-PWG-NFR	Matrix Stack Chair with Chrome Sled Base, Warm Grey Poly Back and Seat	98
CH-4	Allseating	16030-PY-H	Dove Lab Chair- Standard Height with Hard Surface Casters	15
T-1	KI	ENDRC2448/1-73P-N-4GB-15	Enlite Tables Powered with Fixed Leg and 3/4" Laminate Top- 73P Edge, No Casters- 15' cord length	8
T-2	KI	ENRC2448-73P-XX-N-4EC	Enlite Table- Fixed Leg- 3/4" Laminate Top with 73P Edge- No Power with Casters	8
T-5	KI, Inc.	HULN2460-ME-XX-XX-CH-4CB	Hurry Up Table with 4 Black Casters- No Power	26
T-8	KI, Inc.	HULN3060-ME-XX-XX-CH-4CB	Hurry Up Table with 4 Black Casters- No Power	9
<b>03 LEVEL 1</b>				
CH-4	Allseating	16030-PY-H	Dove Lab Chair- Standard Height with Hard Surface Casters	20
<b>04 LEVEL 2</b>				
CH-1	KI	MX-NS-CH-PWG-NFR	Matrix Stack Chair with Chrome Sled Base, Warm Grey Poly Back and Seat	3
T-2	KI	ENRC2448-73P-XX-N-4EC	Enlite Table- Fixed Leg- 3/4" Laminate Top with 73P Edge- No Power with Casters	5

<b>MOODY•NOLAN</b> RESPONSIVE ARCHITECTURE 1225 Eye Street NW Suite 210 Washington, DC 20005 Phone: (202) 244-4199 Fax: (202) 244-2997 www.moodynolan.com	SCHOOL OF ENGINEERING AND APPLIED SCIENCE LABORATORY RENOVATION UNIVERSITY OF DISTRICT OF COLUMBIA 4200 CONNECTICUT AVENUE, WASHINGTON, DC 20008 Fax: (###) ###-#### Phone: (###) ###-####	ISSUED WITH	SHEET REVISED
			A-800
		SKETCH NUMBER	
		<b>A-800a</b>	
PROJ #	DRAWN BY	DATE	
13334.01	Author	01/31/14	



SIGNAGE TYPES

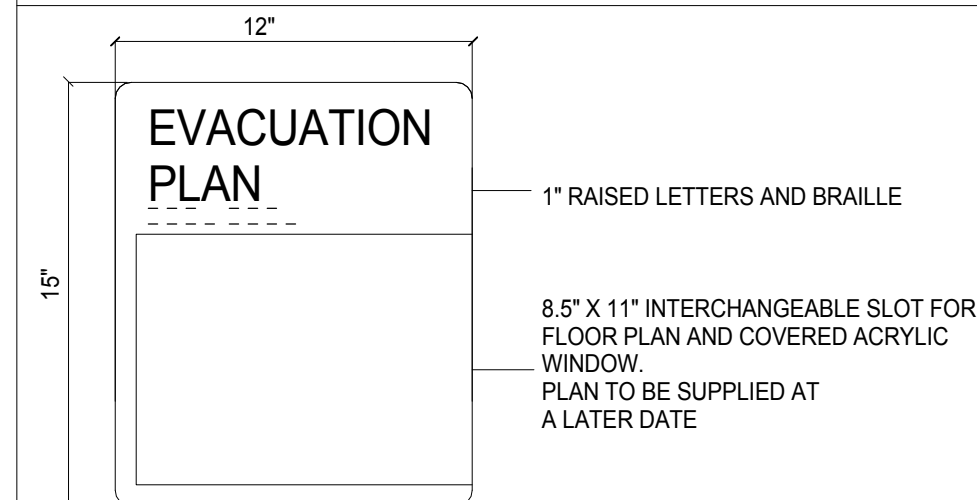

INTERIOR SIGNAGE TYPE D.1

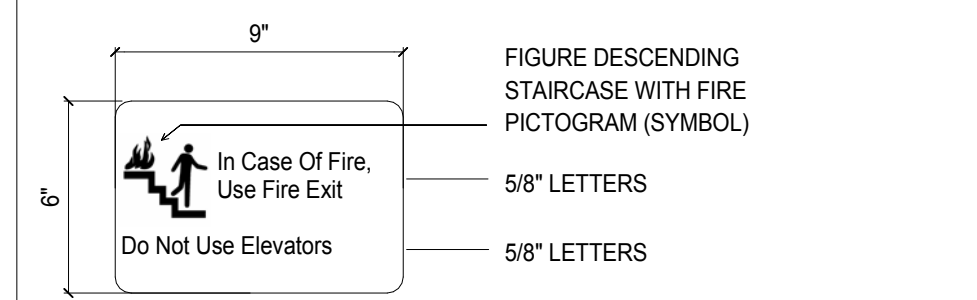

INTERIOR SIGNAGE TYPE D.2

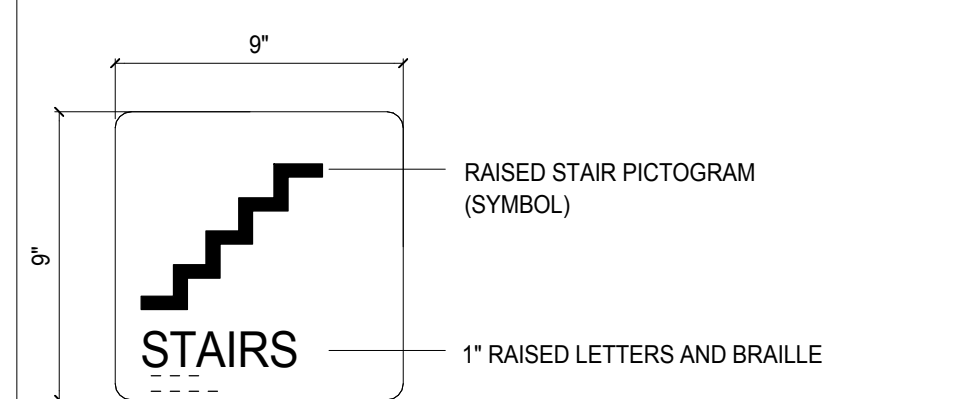

INTERIOR SIGNAGE TYPE E.1

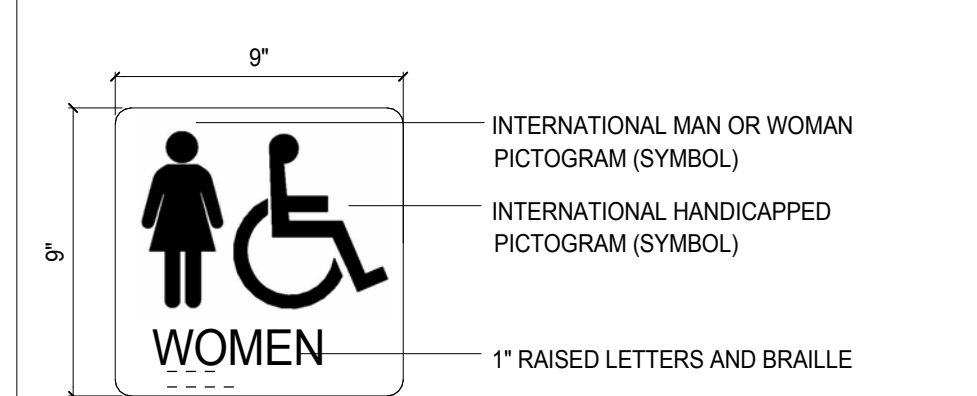

INTERIOR SIGNAGE TYPE E.2w

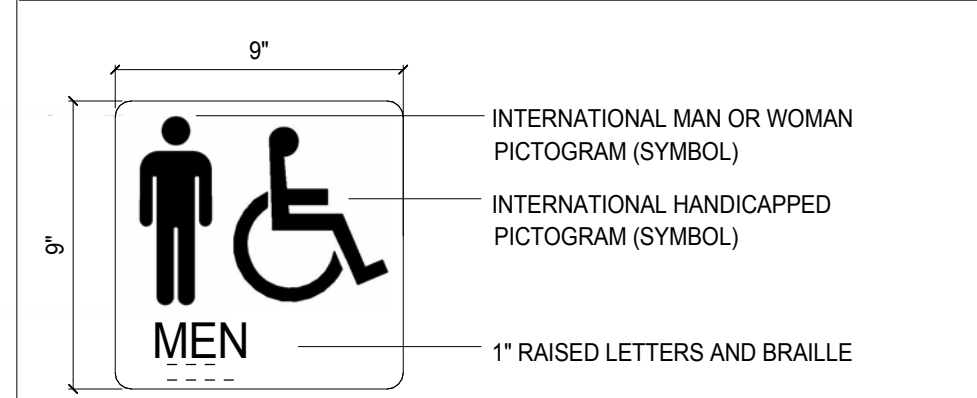

INTERIOR SIGNAGE TYPE E.2m

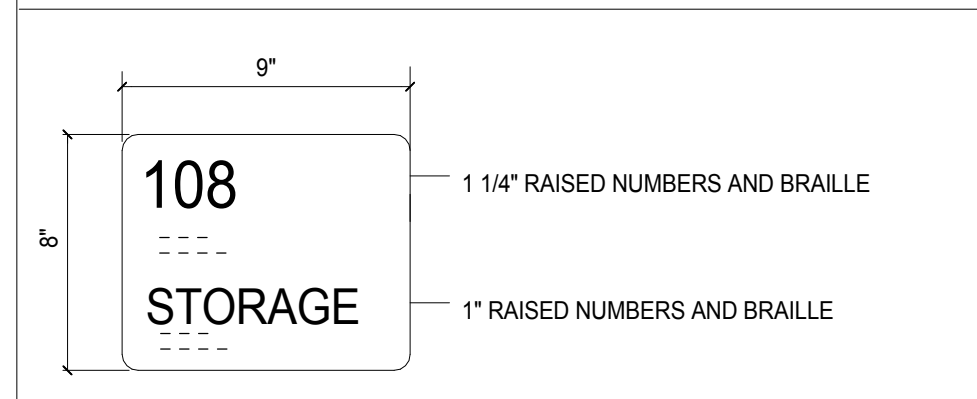

INTERIOR SIGNAGE TYPE E.3

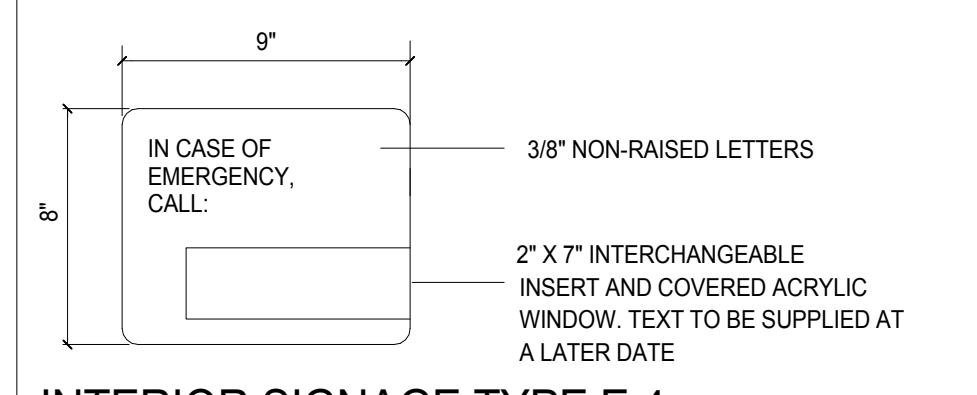

INTERIOR SIGNAGE TYPE E.4

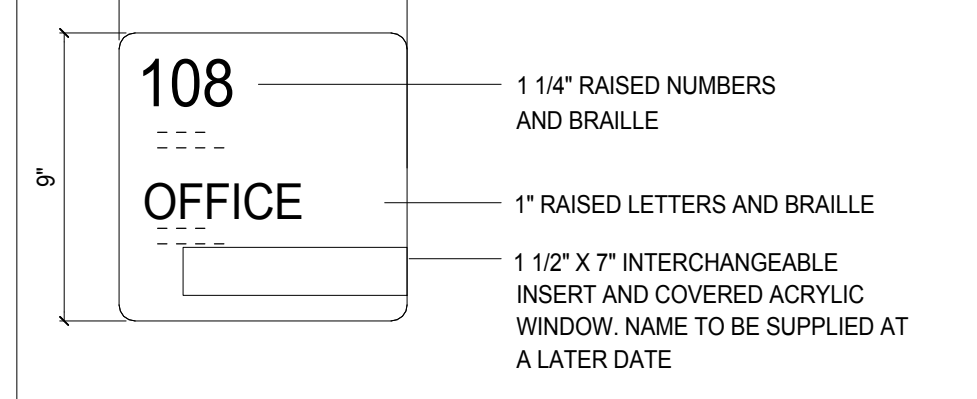

INTERIOR SIGNAGE TYPE J

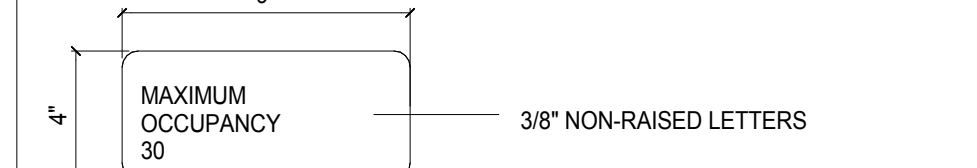

INTERIOR SIGNAGE TYPE L

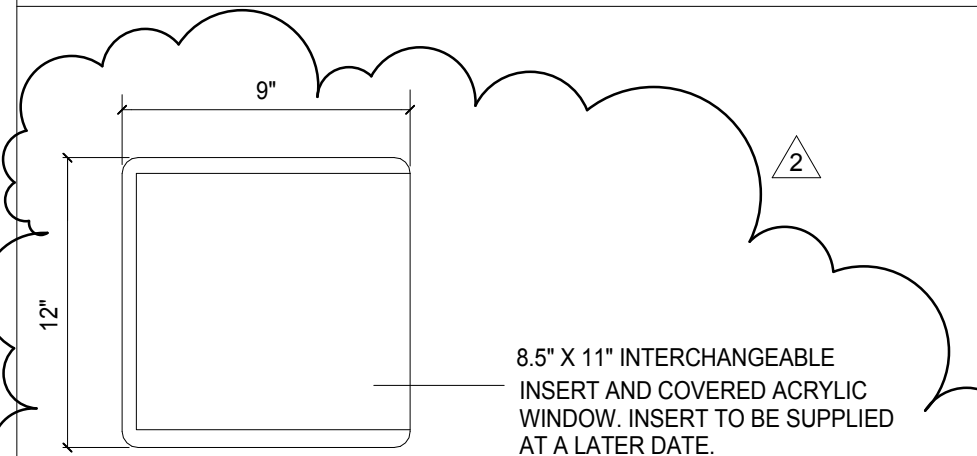

INTERIOR SIGNAGE TYPE N

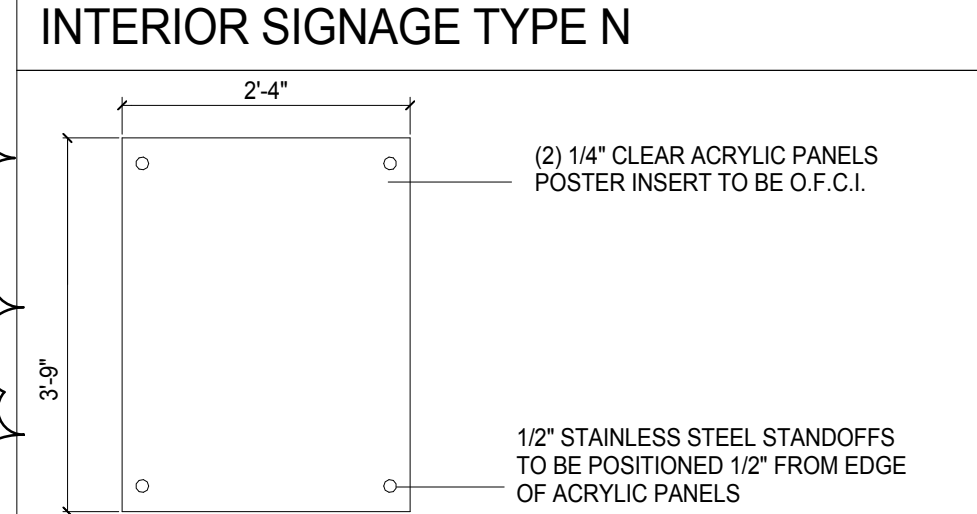

INTERIOR SIGNAGE TYPE P



Table: SIGNAGE SCHEDULE LEVEL C. Columns: Room: Level, Room: Number, Room: Name, Plan Code, Sign Type, Braille, Copy Number, Copy - Line 1. Rows include various labs and offices on Level C.

Table: SIGNAGE SCHEDULE LEVEL A, 1, AND 2. Columns: Room: Level, Room: Number, Room: Name, Plan Code, Sign Type, Braille, Copy Number, Copy - Line 1. Rows include various labs and offices on Levels A, 1, and 2.

NOTE: REFER TO ABOVE SIGNAGE SCHEDULE FOR LOCATIONS OF THESE REVISED SIGN TYPES

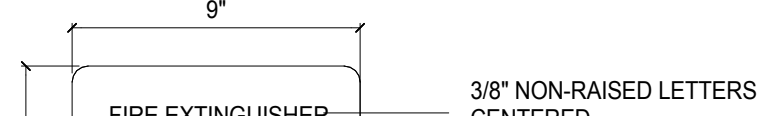

INTERIOR SIGNAGE TYPE F

Table: SIGNAGE SCHEDULE LEVEL C. Columns: Room: Level, Room: Number, Room: Name, Plan Code, Sign Type, Braille, Copy Number, Copy - Line 1. Rows include various labs and offices on Level C.

Table: SIGNAGE SCHEDULE LEVEL C. Columns: Room: Level, Room: Number, Room: Name, Plan Code, Sign Type, Braille, Copy Number, Copy - Line 1. Rows include various labs and offices on Level C.

Table: SIGNAGE SCHEDULE LEVEL C. Columns: Room: Level, Room: Number, Room: Name, Plan Code, Sign Type, Braille, Copy Number, Copy - Line 1. Rows include various labs and offices on Level C.

Table: SIGNAGE SCHEDULE LEVEL C. Columns: Room: Level, Room: Number, Room: Name, Plan Code, Sign Type, Braille, Copy Number, Copy - Line 1. Rows include various labs and offices on Level C.

Table: SIGNAGE SCHEDULE LEVEL C. Columns: Room: Level, Room: Number, Room: Name, Plan Code, Sign Type, Braille, Copy Number, Copy - Line 1. Rows include various labs and offices on Level C.

Table: SIGNAGE SCHEDULE LEVEL C. Columns: Room: Level, Room: Number, Room: Name, Plan Code, Sign Type, Braille, Copy Number, Copy - Line 1. Rows include various labs and offices on Level C.

Table: SIGNAGE SCHEDULE LEVEL C. Columns: Room: Level, Room: Number, Room: Name, Plan Code, Sign Type, Braille, Copy Number, Copy - Line 1. Rows include various labs and offices on Level C.

SIGNAGE SHEET NOTES

- 1. GENERAL CONTRACTOR SHALL MEET WITH OWNER TO VERIFY ROOM NUMBERS FOR ALL SIGNS...
2. ALL PERMANENT ROOM SIGNS WITH NUMBERS AND/OR SYMBOLS SHALL MEET ADA FACILE...
3. ALL SIGNS TO BE MOUNTED ON LATCH SIDE OF DOOR...
4. MOUNT SIGNS 6\"/>

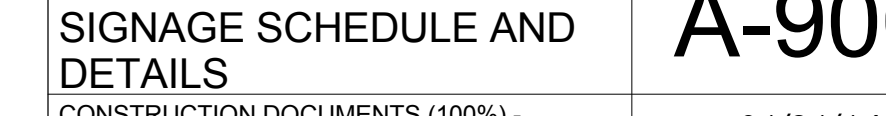
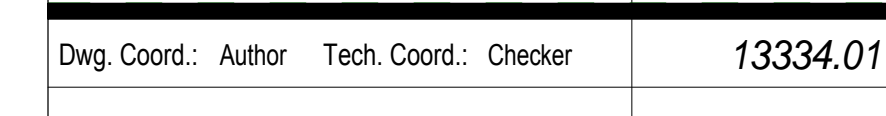
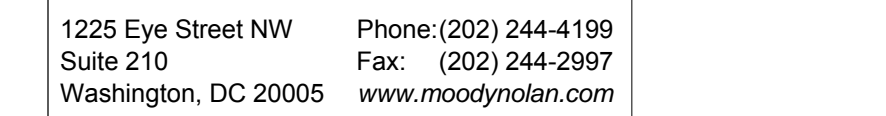
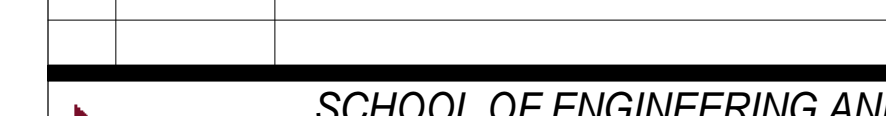
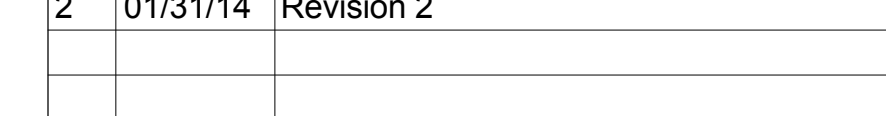
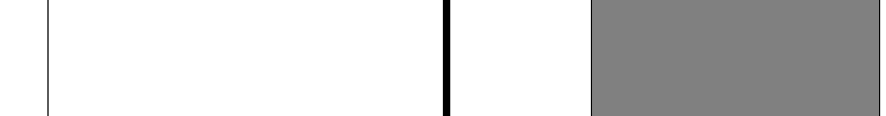
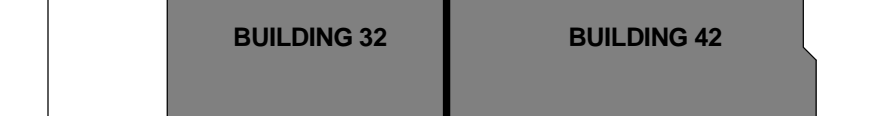

1 Construction sign 1\"/>

KEY PLAN

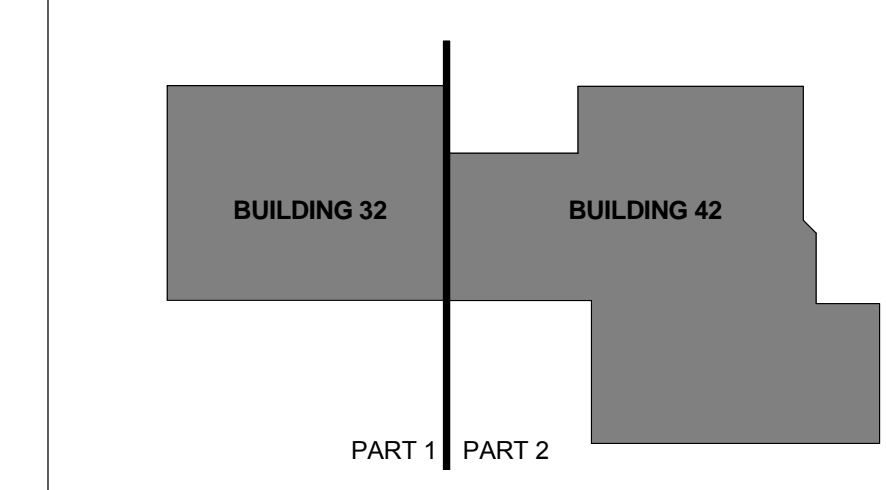

Project information block for University of the District of Columbia, including project name, dates, and contact information for Dr. James E. Lyons, Sr., Dr. Rachel Petty, Erik L. Thompson, and UDC Capital Construction Division.

School of Engineering and Applied Sciences Laboratory Renovation project information, including address and contact details for the University of the District of Columbia.

Moody Nolan Responsive Architecture logo and contact information, including address and phone/fax numbers.

Dwg Coord.: Author Tech. Coord.: Checker 13334.01

SIGNAGE SCHEDULE AND DETAILS CONSTRUCTION DOCUMENTS (100%) - ISSUE FOR BID 01/31/14

A-900



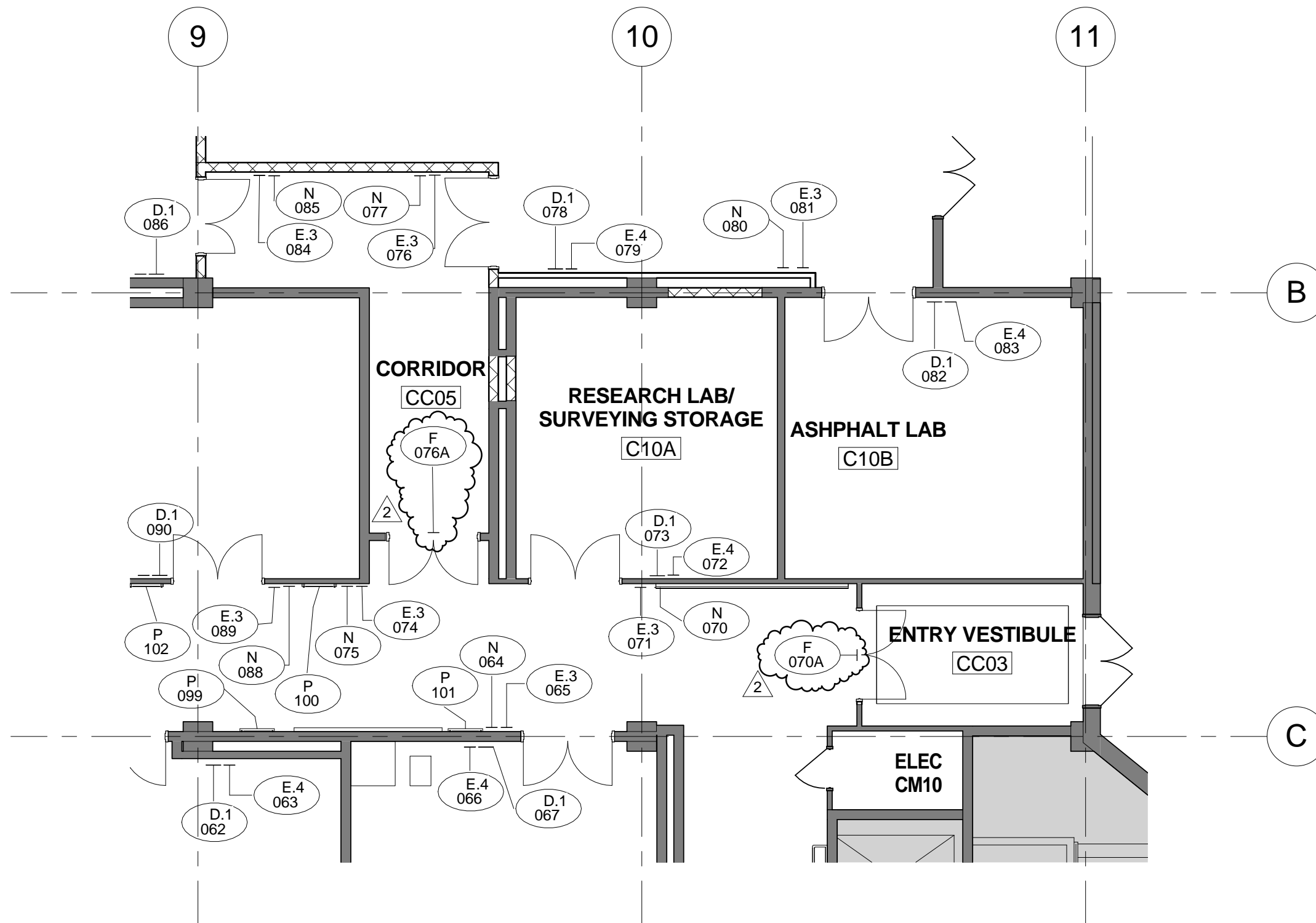

**2** Addendum - SIGNAGE - LEVEL C - PART 2  
 1/8" = 1'-0"

<b>MOODY•NOLAN</b> RESPONSIVE ARCHITECTURE 1225 Eye Street NW Suite 210 Washington, DC 20005 Phone: (202) 244-4199 Fax: (202) 244-2997 www.moodynolan.com		SCHOOL OF ENGINEERING AND APPLIED SCIENCE LABORATORY RENOVATION UNIVERSITY OF DISTRICT OF COLUMBIA 4200 CONNECTICUT AVENUE, WASHINGTON, DC 20008 Fax: (###) ###-#### Phone: (###) ###-####		ISSUED WITH SHEET REVISED A-901
		SKETCH NUMBER <b>A-901a</b>		PROJ # 13334.01
		DRAWN BY Author	DATE 01/31/14	

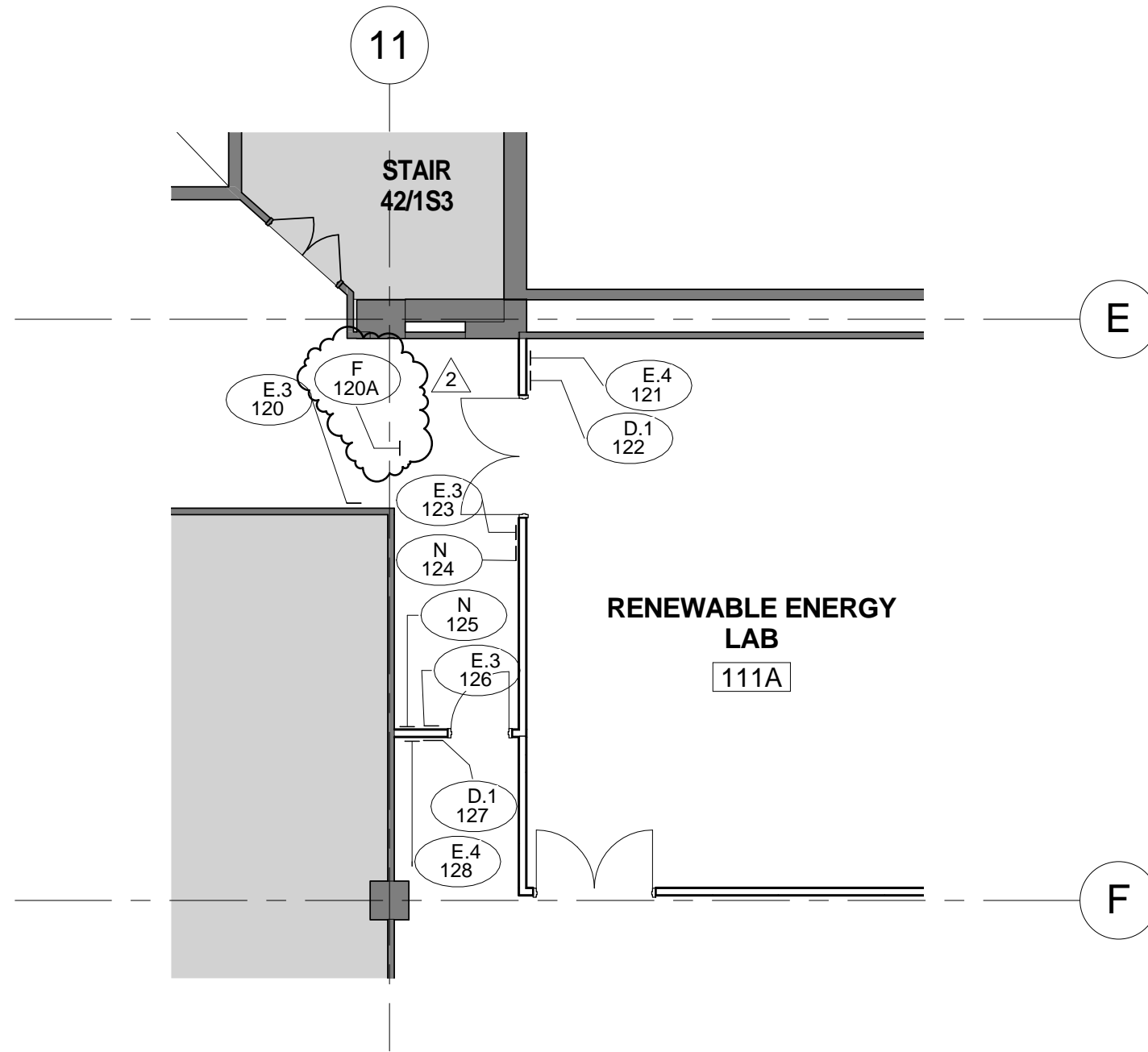

**1** ADDENDUM - SIGNAGE - LEVEL 1  
 1/8" = 1'-0"

<b>MOODY•NOLAN</b> RESPONSIVE ARCHITECTURE 1225 Eye Street NW Suite 210 Washington, DC 20005 Phone: (202) 244-4199 Fax: (202) 244-2997 www.moodynolan.com		SCHOOL OF ENGINEERING AND APPLIED SCIENCE LABORATORY RENOVATION UNIVERSITY OF DISTRICT OF COLUMBIA 4200 CONNECTICUT AVENUE, WASHINGTON, DC 20008 Fax: (###) ###-#### Phone: (###) ###-####		ISSUED WITH SHEET REVISED A-902
		SKETCH NUMBER <b>A-902a</b>		PROJ # 13334.01
		DRAWN BY Author	DATE 01/31/14	



© 2012 Moody/Nolan Inc. 18/2014 4:52:12 PM C:\Local Revit Projects\13334-01 UDCC SEAS LAB\_R2013\_CENTRAL\_PP.puramk.dwt

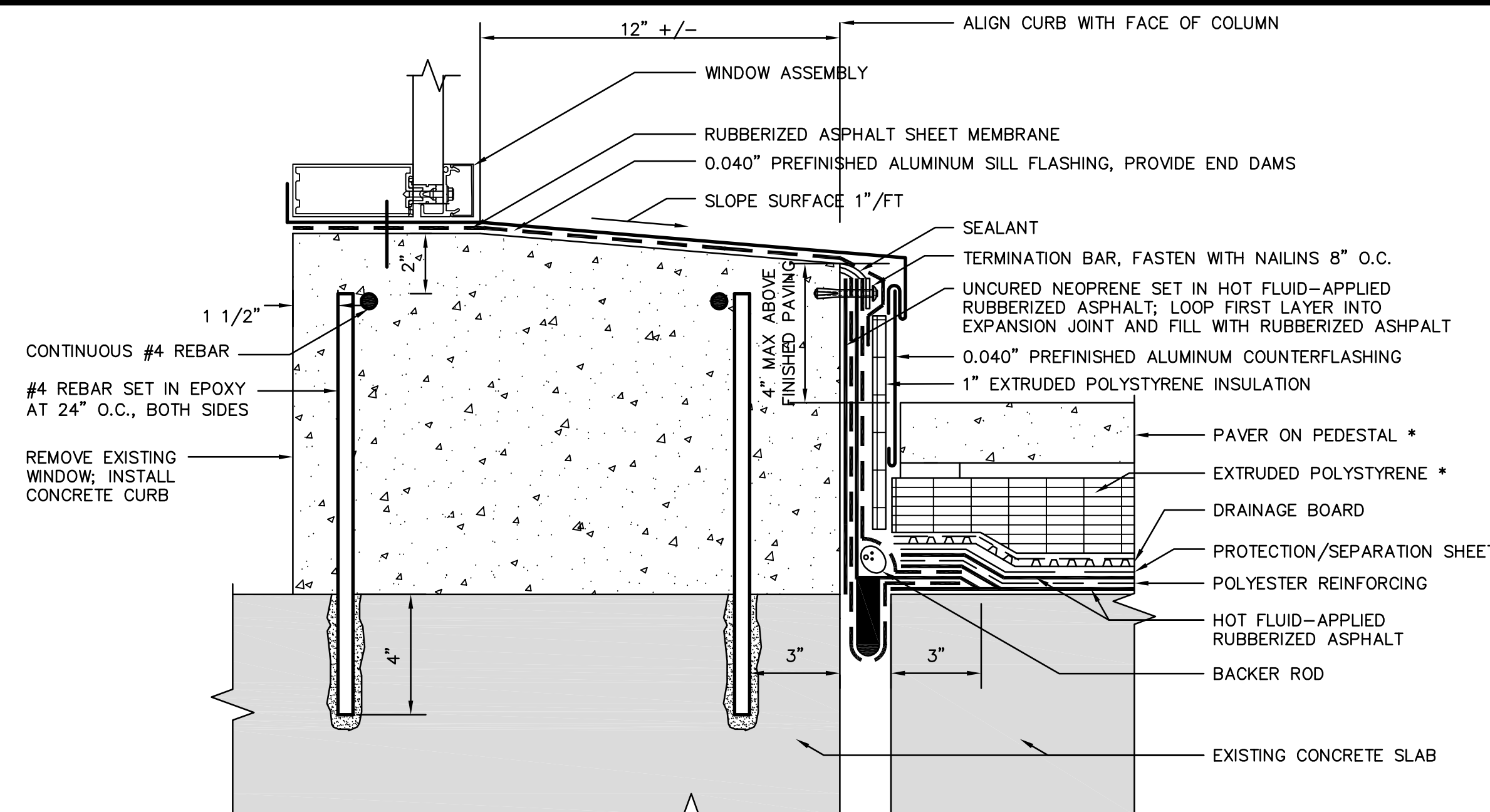

**1 EXP. JOINT AT WINDOW PLAZA LEVEL**  
SCALE: 3" = 1'-0"

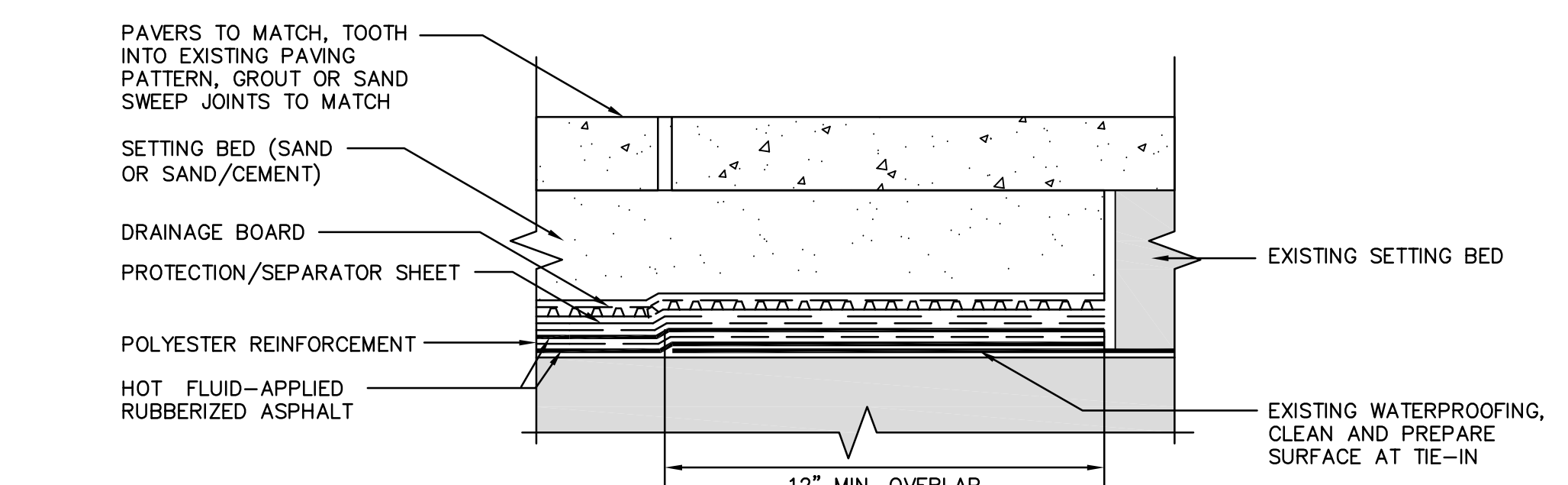

**4 TYPICAL PLAZA TIE IN**  
SCALE: 3" = 1'-0"

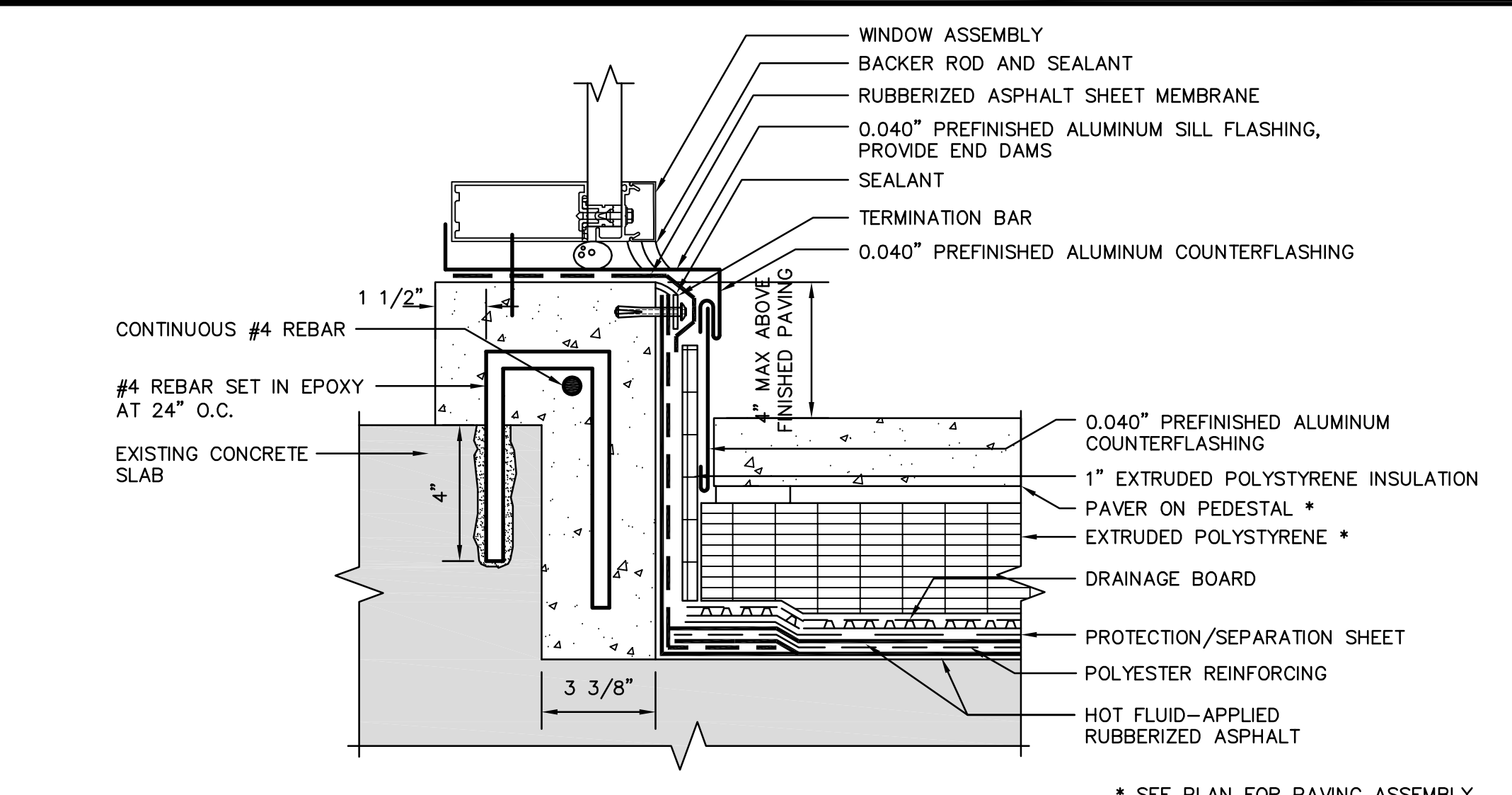

**2 TYPICAL WINDOW SILL PLAZA LEVEL**  
SCALE: 3" = 1'-0"

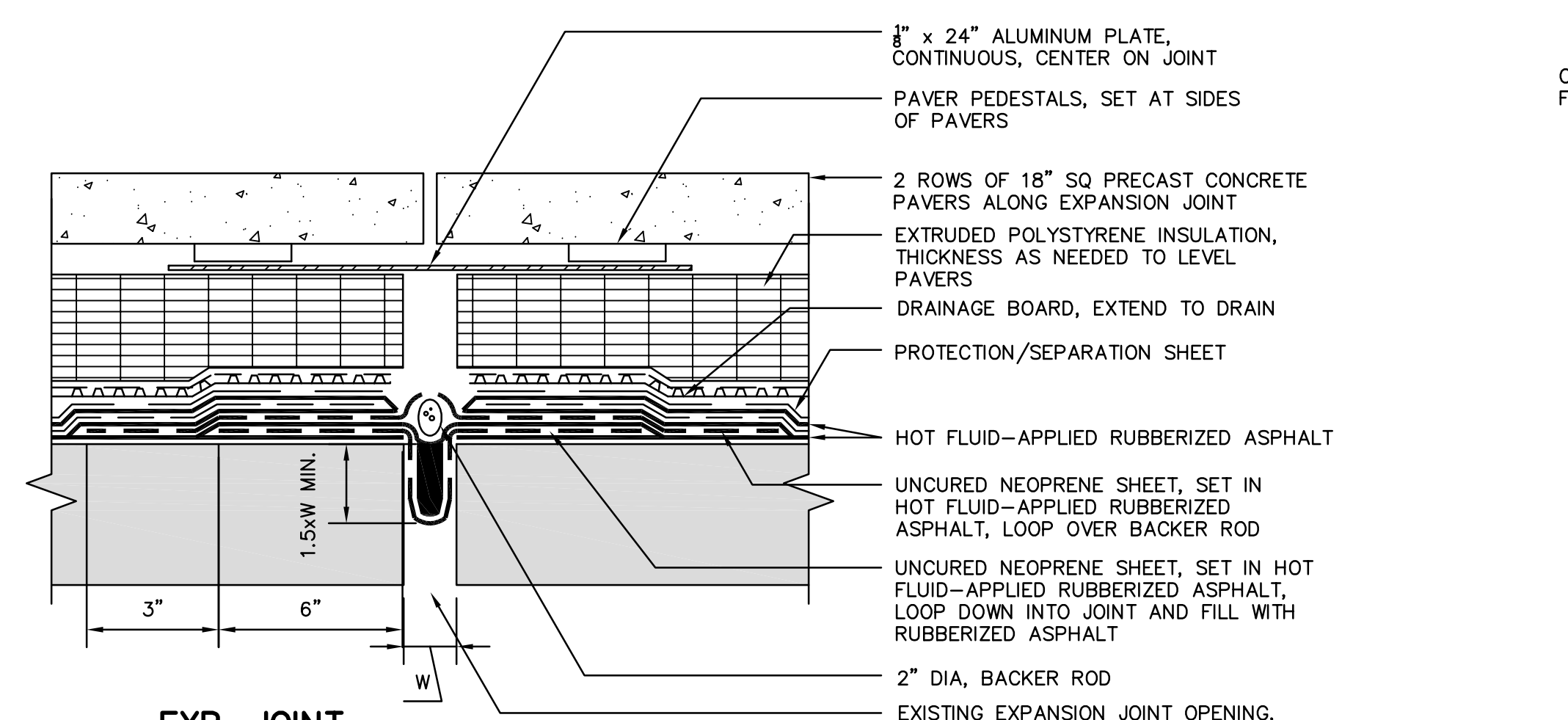

**5 EXP. JOINT AT PLAZA DECK**  
SCALE: 3" = 1'-0"

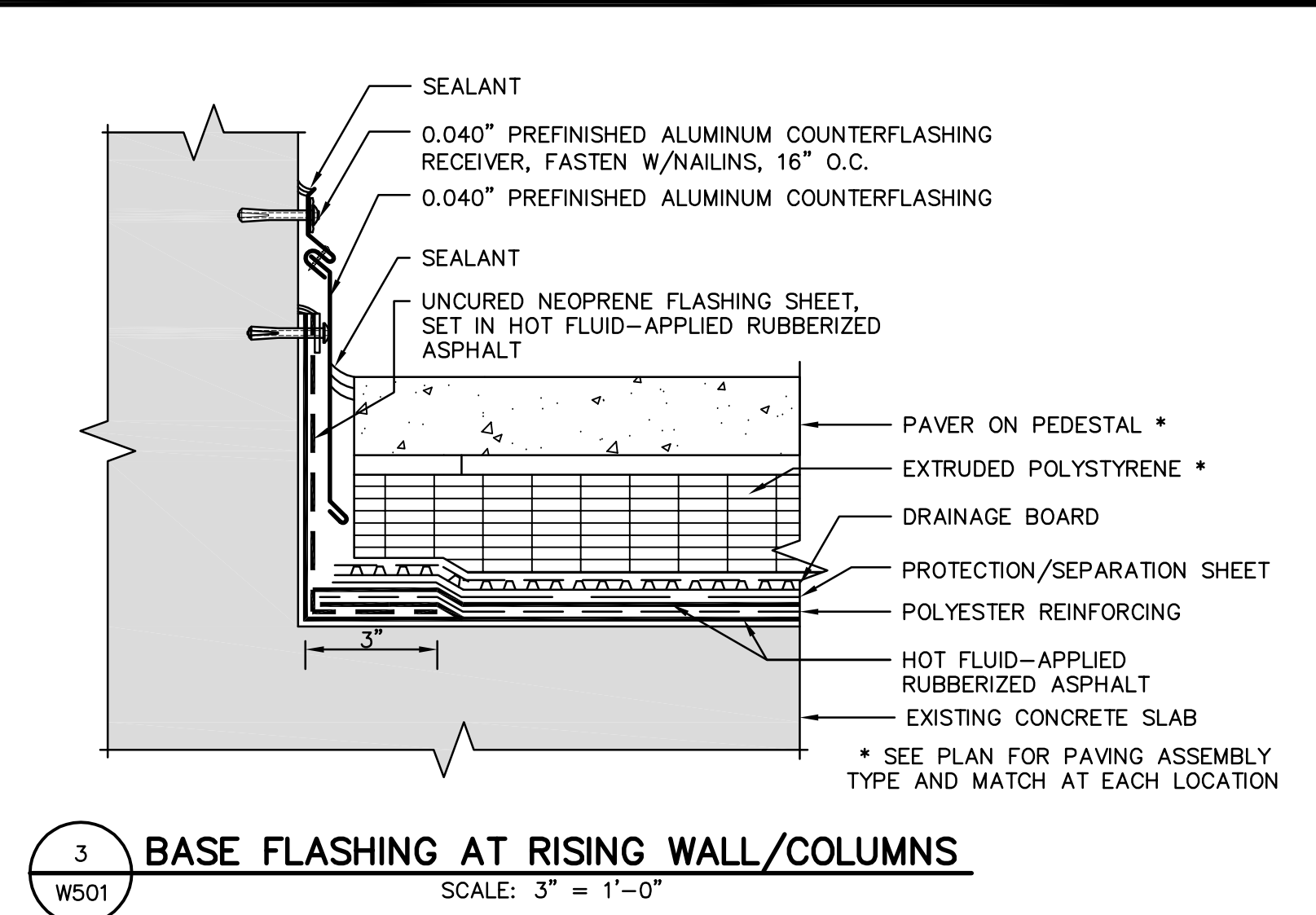

**3 BASE FLASHING AT RISING WALL/COLUMNS**  
SCALE: 3" = 1'-0"

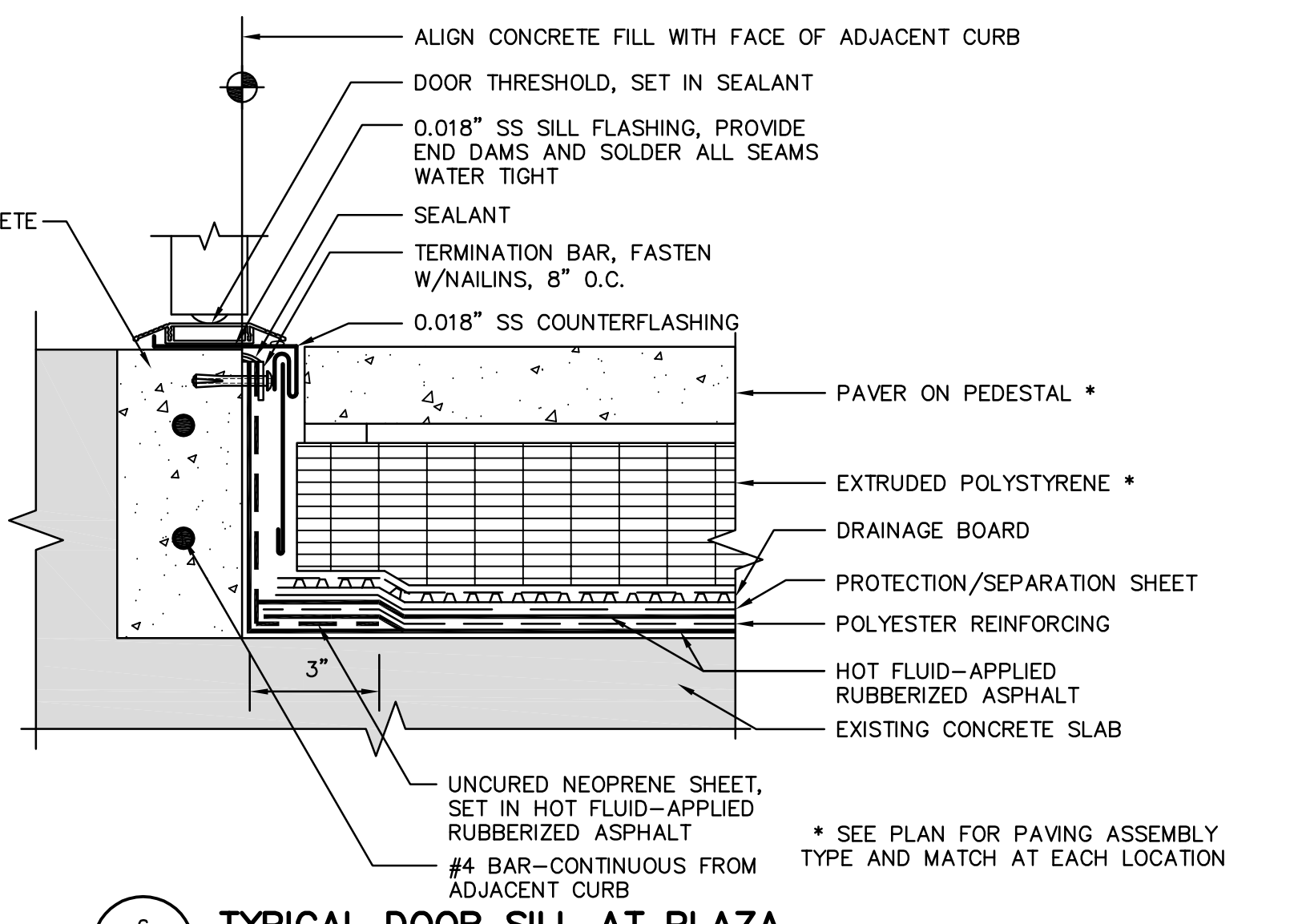

**6 TYPICAL DOOR SILL AT PLAZA**  
SCALE: 3" = 1'-0"

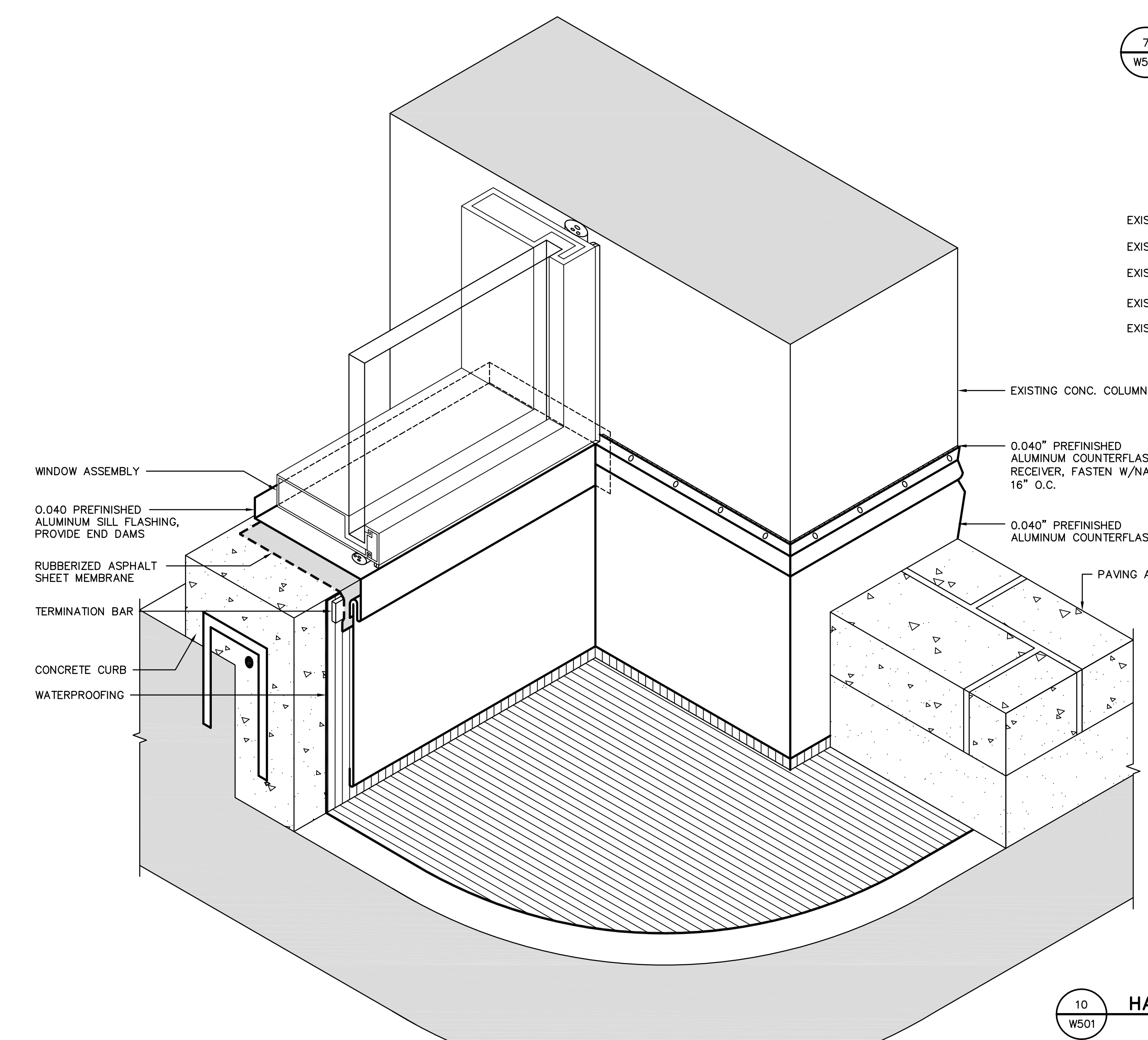

**12 WINDOW WALL TERMINATION AT CONCRETE COLUMN**  
SCALE: 3" = 1'-0"

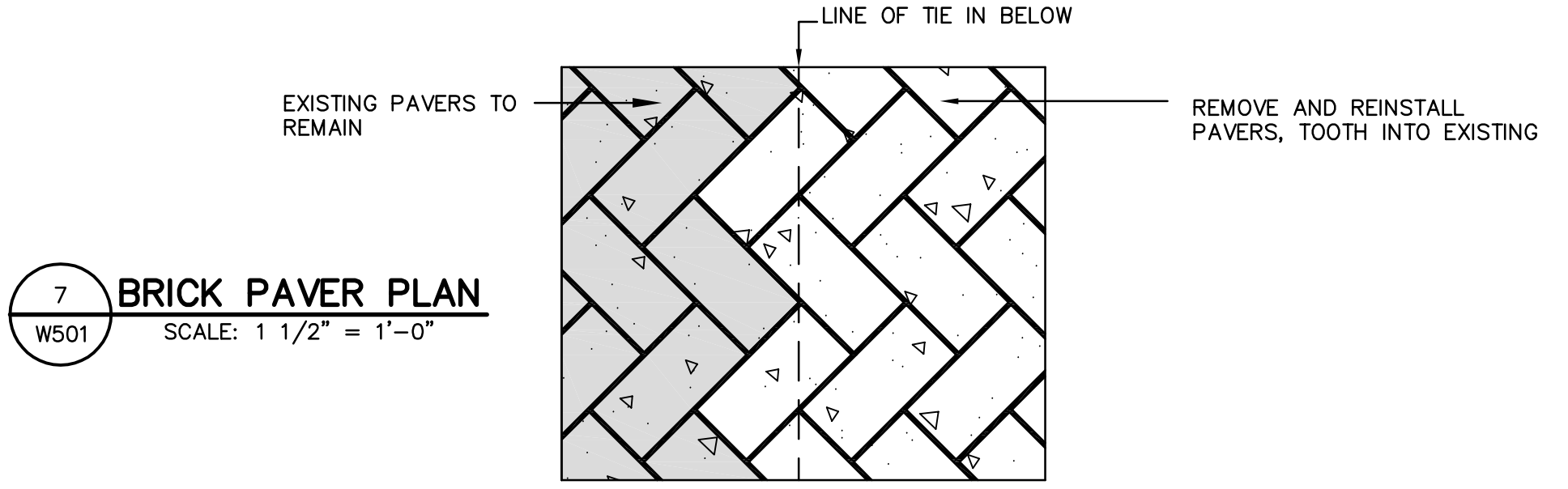

**7 BRICK PAVER PLAN**  
SCALE: 1 1/2" = 1'-0"

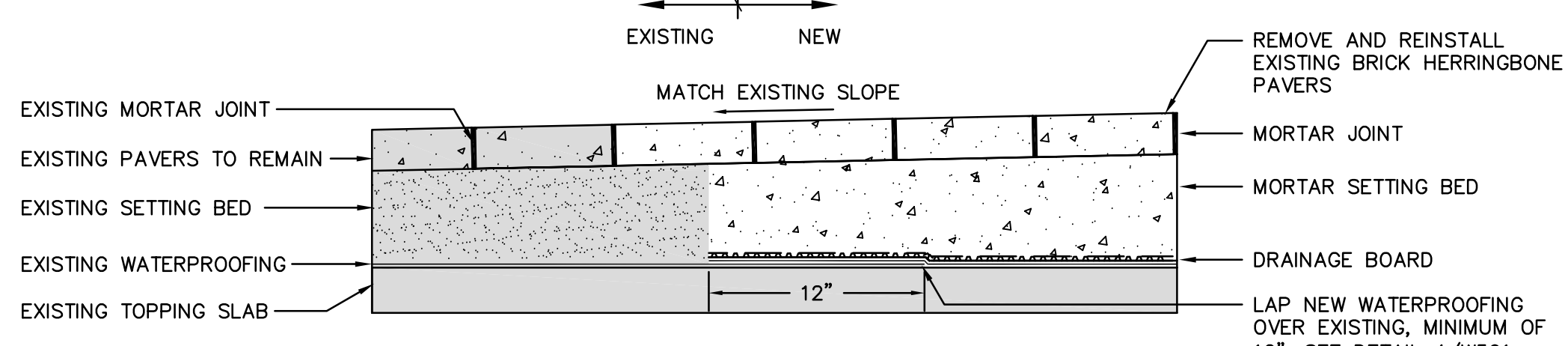

**8 BRICK PAVING ASSEMBLY**  
SCALE: 1 1/2" = 1'-0"

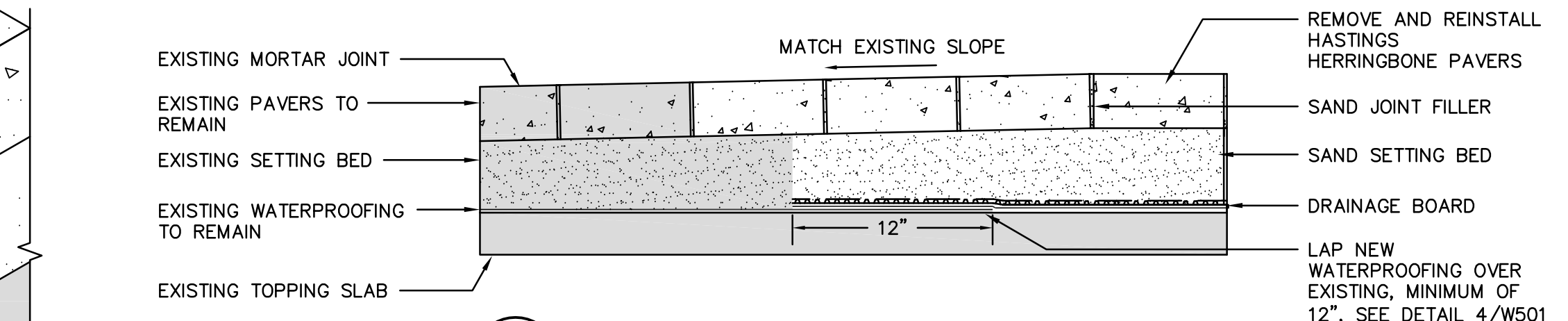

**9 HASTINGS BRICK PAVERS ASSEMBLY**  
SCALE: 1 1/2" = 1'-0"

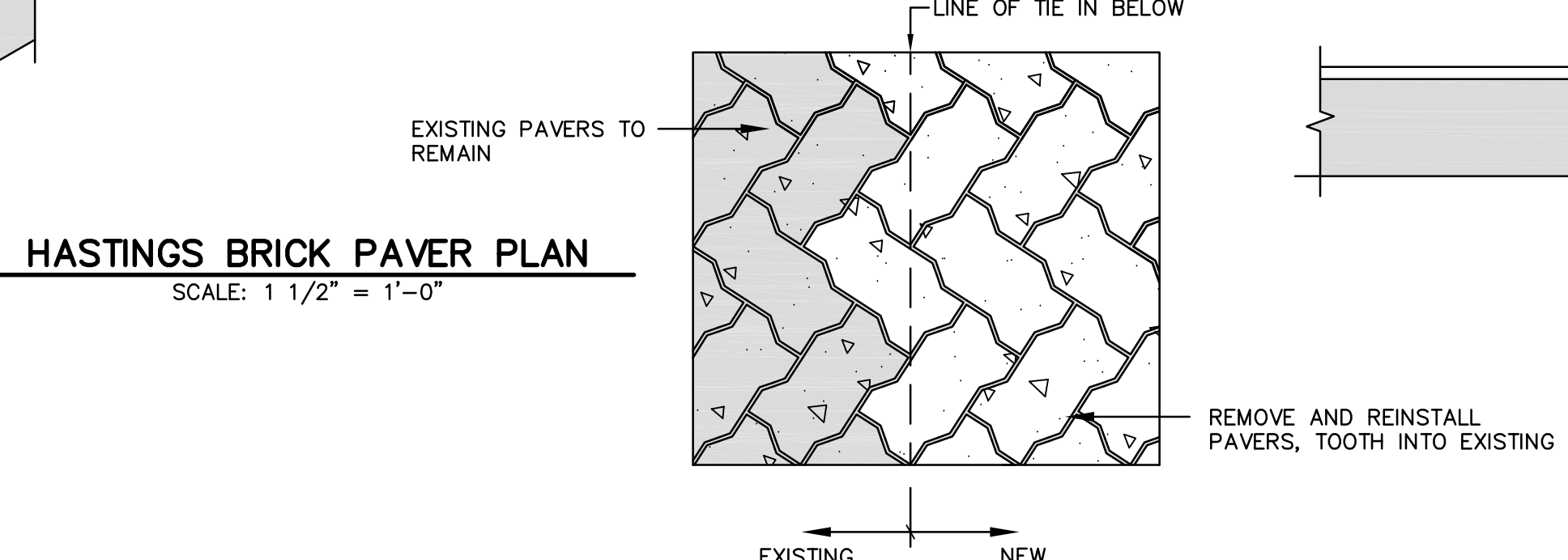

**10 HASTINGS BRICK PAVER PLAN**  
SCALE: 1 1/2" = 1'-0"

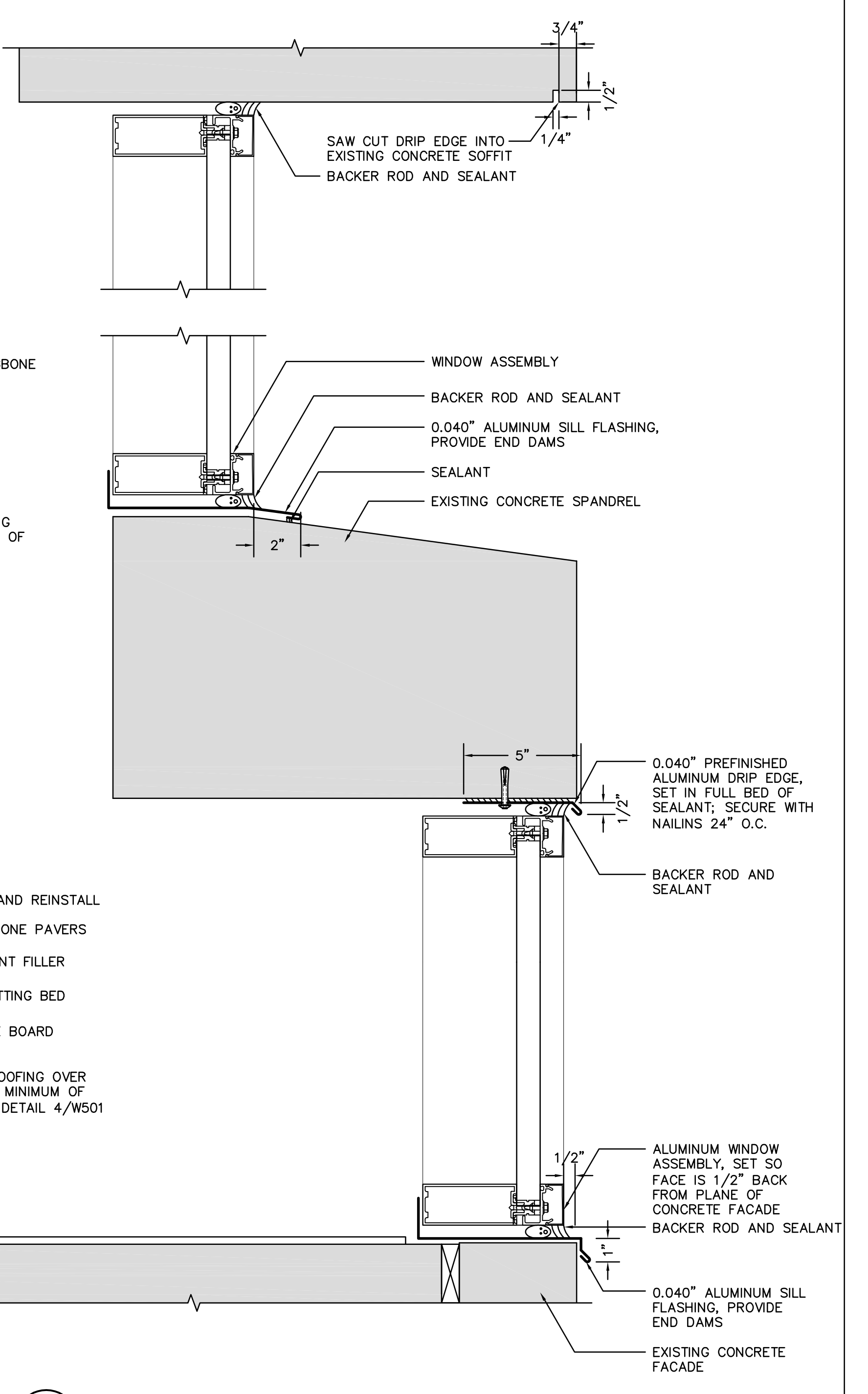

**11 FLASHING AT UPPER LEVEL WINDOW INSTALLATIONS**  
SCALE: 3" = 1'-0"

**KEY PLAN**

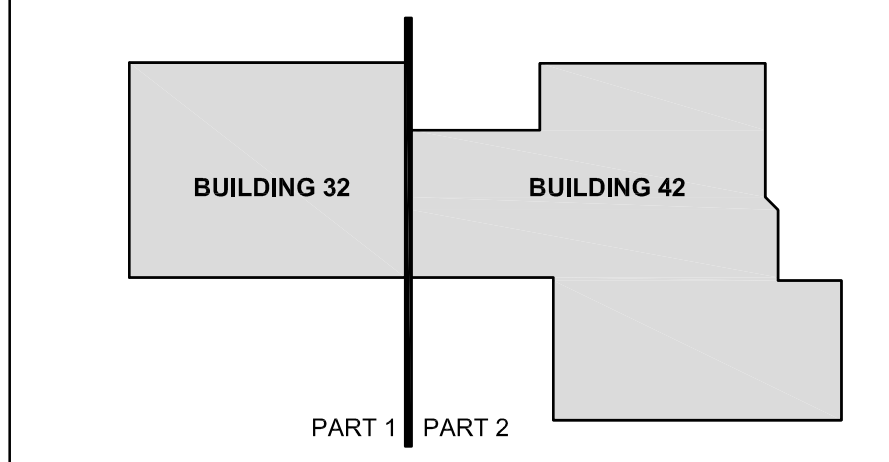

#	Date	Change Description
1	1/31/14	REVISION 2

**SCHOOL OF ENGINEERING AND APPLIED SCIENCES LABORATORY RENOVATION**  
4200 CONNECTICUT AVENUE, WASHINGTON, DC 20008  
UNIVERSITY OF DISTRICT OF COLUMBIA  
UNIVERSITY OF DISTRICT OF COLUMBIA

**MOODY·NOLAN**  
RESPONSIVE ARCHITECTURE  
1225 Eye Street NW Suite 210 Washington, DC 20005 Phone: (202) 244-4199 Fax: (202) 244-2997 www.moodynolan.com

Dwg. Coord.: MAH Tech. Coord.: DAF 13334.01  
**WATERPROOFING DETAILS**  
CONSTRUCTION DOCUMENTS (100%) - ISSUE FOR BID  
**W-501**  
01/31/2014



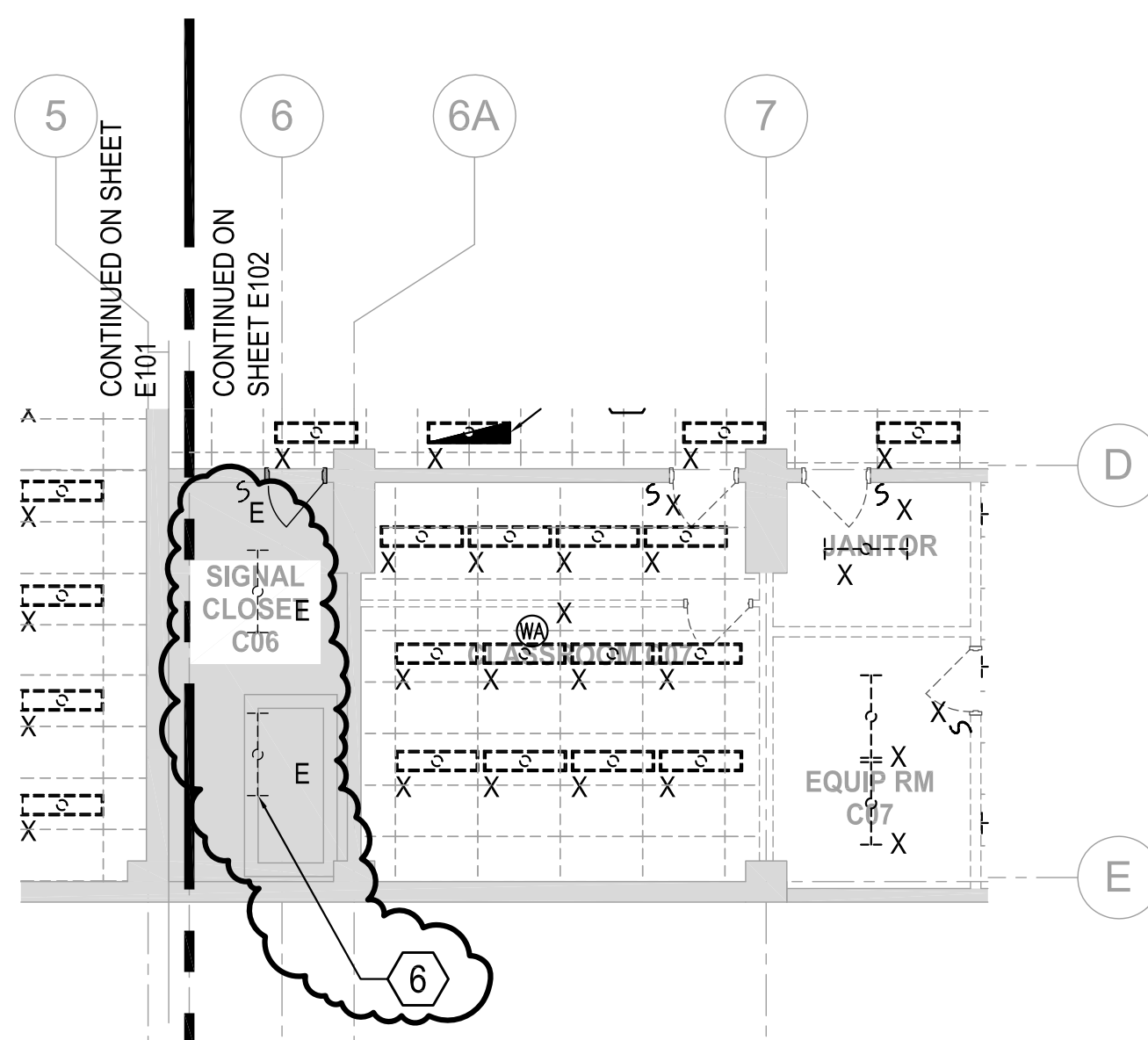

**DEMOLITION KEY NOTES(PARTIAL):**

⬡ LIGHT FIXTURES AND LIGHT SWITCHES TO REMAIN IN THIS ROOM. DISCONNECT LIGHTING CIRCUIT SERVING THIS ROOM AND RETAIN FOR RECONNECTION. SEE DWG E-104,

**LEVEL C  
PART PLAN DRAWING 102- LIGHTING - DEMOLITION**

SCALE: 1/8" = 1'-0"

<b>MOODY•NOLAN</b> RESPONSIVE ARCHITECTURE 1225 Eye Street NW Suite 210 Washington, DC 20005 Phone: (202) 244-4199 Fax: (202) 244-2997 www.moodynolan.com		SCHOOL OF ENGINEERING AND APPLIED SCIENCE LABORATORY RENOVATION UNIVERSITY OF DISTRICT OF COLUMBIA 4200 CONNECTICUT AVENUE, WASHINGTON, DC 20008 Fax: (###) ###-#### Phone: (###) ###-####		ISSUED WITH	SHEET REVISED
		PROJ # 13334.01		SKETCH NUMBER <b>E102A</b>	DRAWN BY AL

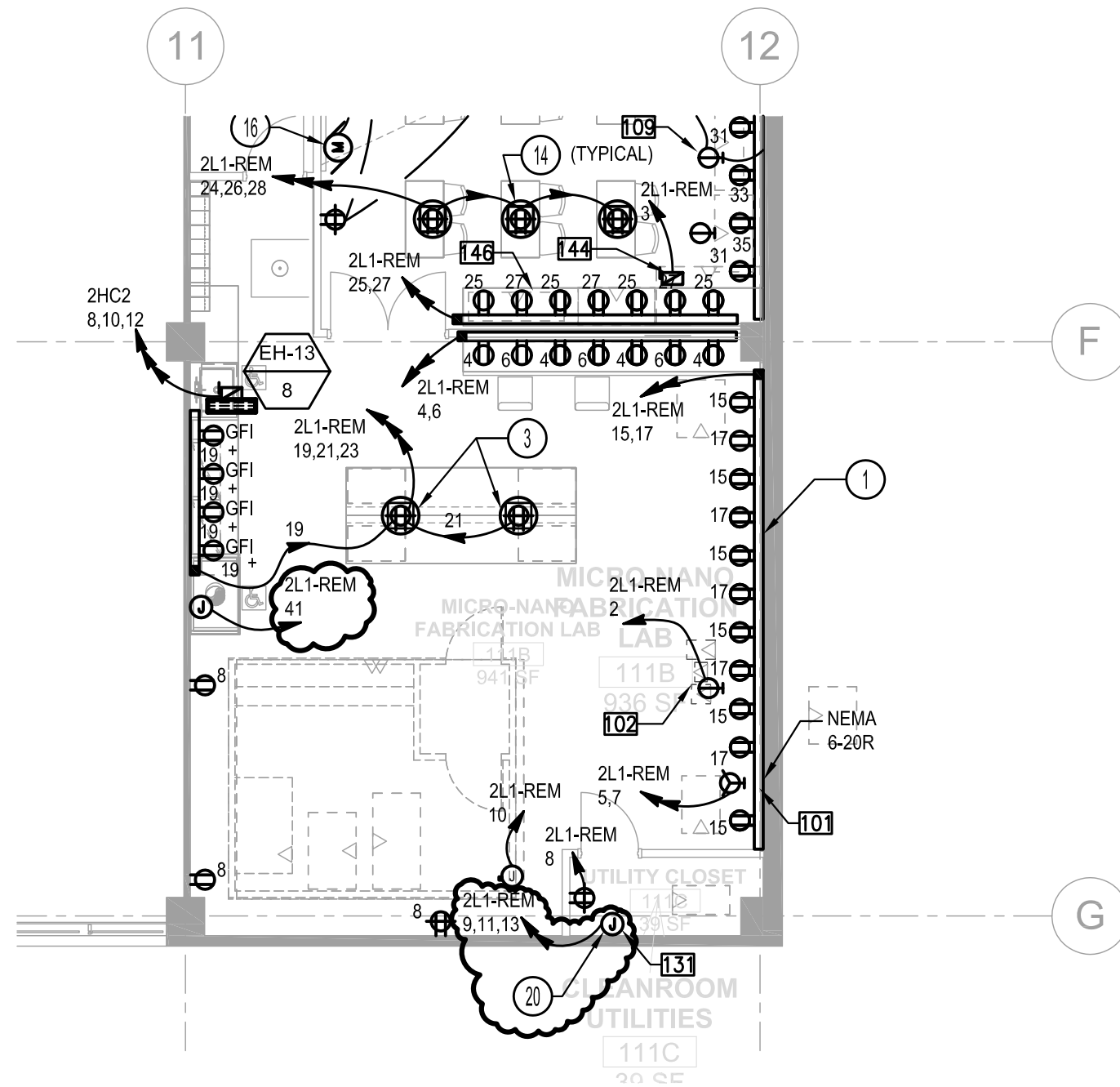

**NEW WORK KEY NOTES (PARTIAL):**

20 JUNCTION BOX FOR MODULAR CLEAN ROOM POWER SUPPLY.

**LEVEL 1**  
**PART PLAN - POWER - NEW WORK**  
 SCALE: 1/8" = 1'-0"

<b>MOODY•NOLAN</b> RESPONSIVE ARCHITECTURE 1225 Eye Street NW Suite 210 Washington, DC 20005 Phone: (202) 244-4199 Fax: (202) 244-2997 www.moodynolan.com		SCHOOL OF ENGINEERING AND APPLIED SCIENCE LABORATORY RENOVATION UNIVERSITY OF DISTRICT OF COLUMBIA 4200 CONNECTICUT AVENUE, WASHINGTON, DC 20008 Fax: (###) ###-#### Phone: (###) ###-####		ISSUED WITH	SHEET REVISED
		PROJ # 13334.01 DRAWN BY AL DATE 01/24/2014		SKETCH NUMBER <b>E112A</b>	

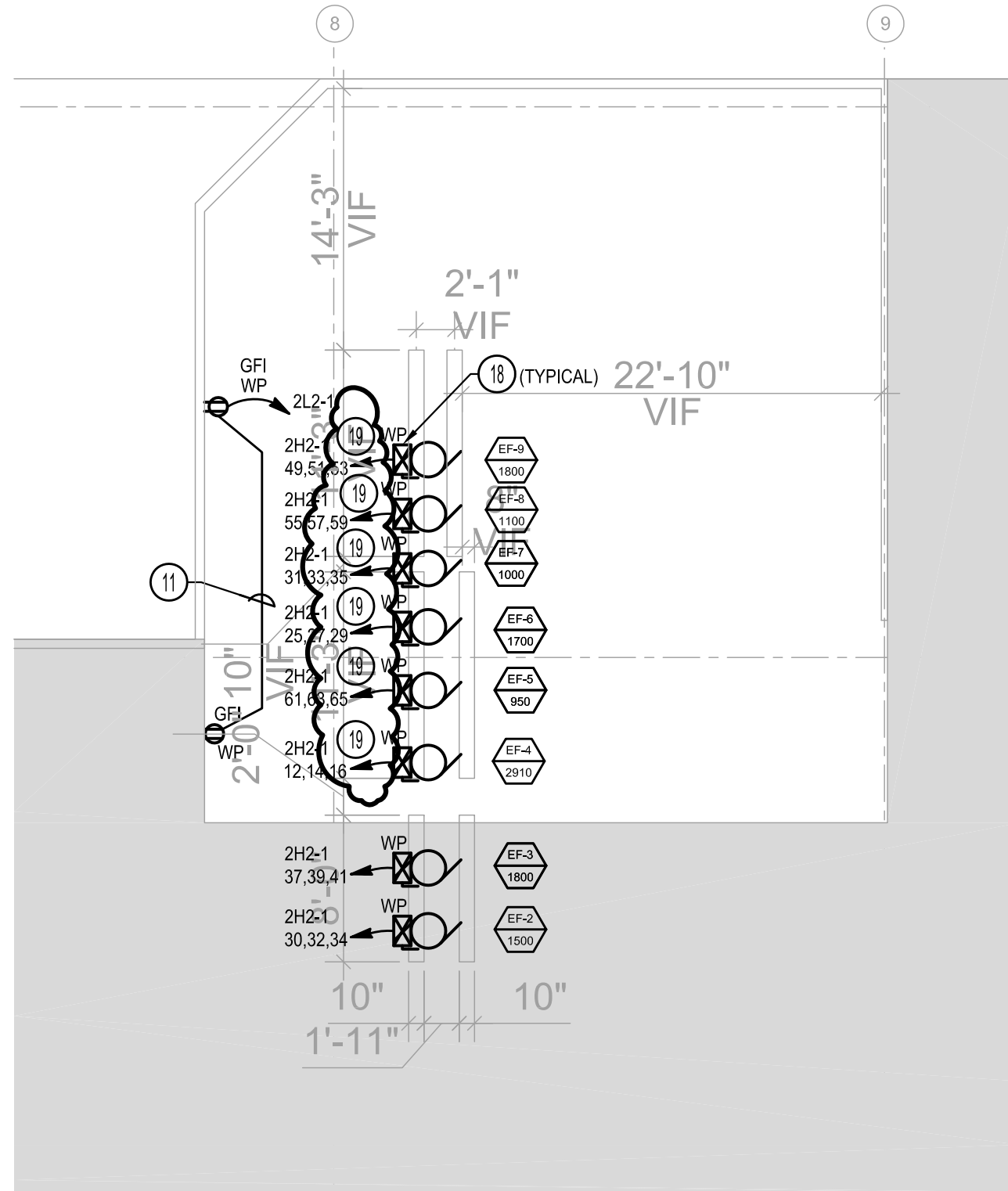

**NEW WORK KEY NOTES (PARTIAL):**

19 RUN NEW HOME RUNS OF NEW FANS TO PANEL 2H2 VIA EXISTING ROOF PENETRATION. CONTRACTOR TO VERIFY.

**ROOF PART PLAN -  
POWER - NEW WORK**

SCALE: 1/8" = 1'-0"

<b>MOODY•NOLAN</b> RESPONSIVE ARCHITECTURE 1225 Eye Street NW Suite 210 Washington, DC 20005 Phone: (202) 244-4199 Fax: (202) 244-2997 www.moodynolan.com		SCHOOL OF ENGINEERING AND APPLIED SCIENCE LABORATORY RENOVATION UNIVERSITY OF DISTRICT OF COLUMBIA 4200 CONNECTICUT AVENUE, WASHINGTON, DC 20008 Fax: (###) ###-#### Phone: (###) ###-####		ISSUED WITH	SHEET REVISED
		SKETCH NUMBER <b>E112B</b>		PROJ #	DRAWN BY
		13334.01	AL	01/24/2014	

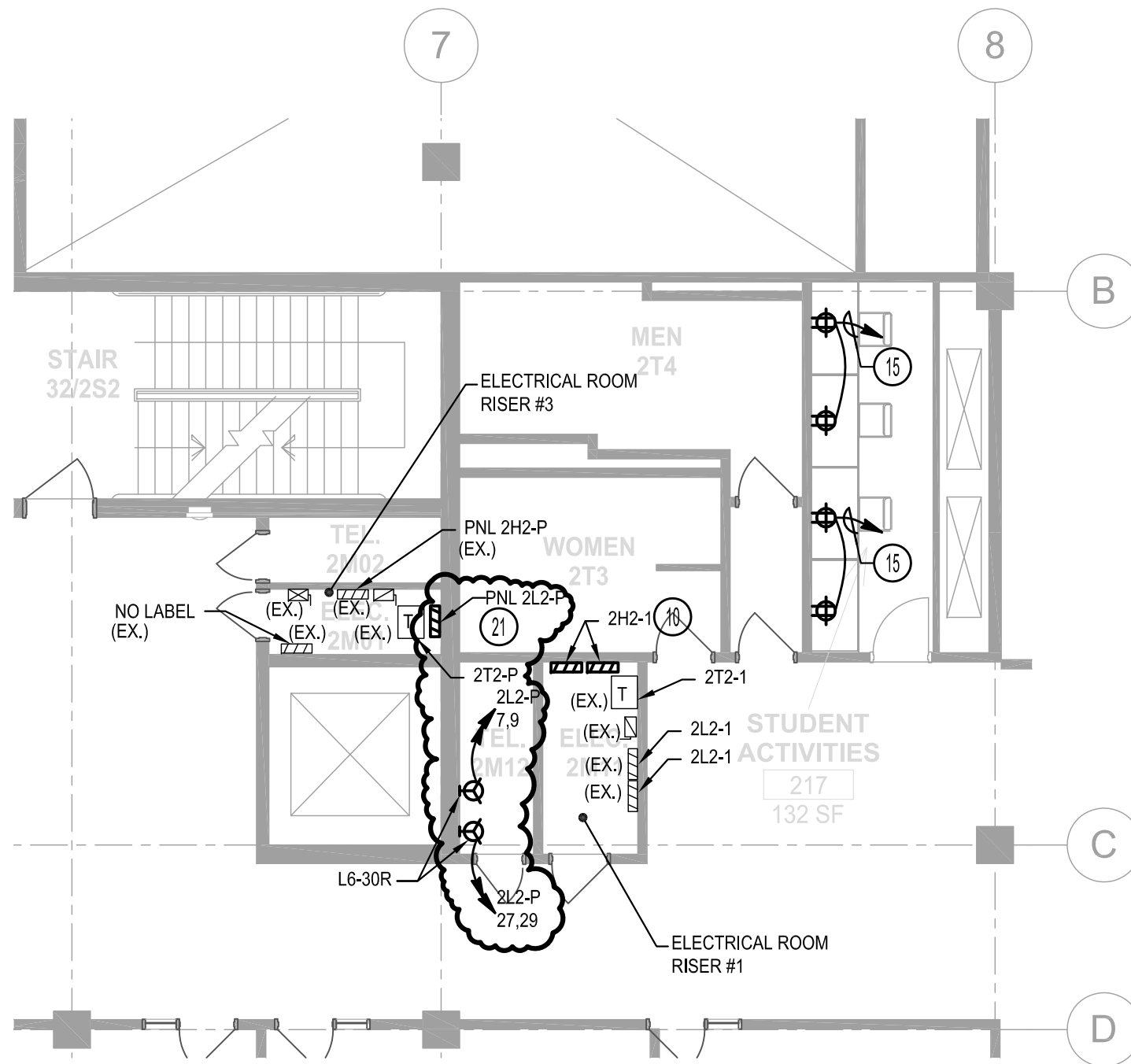

**NEW WORK KEY NOTES (PARTIAL):**

21 REPLACE PANEL 2L2-P WITH NEW NEW PANEL 2L2-P 150A, 208/120V, 3Ø, 4 WIRE. PROVIDE PER PANEL SCHEDULE.

**LEVEL 2  
PART PLAN - POWER - NEW WORK**

SCALE: 1/8" = 1'-0"

<b>MOODY•NOLAN</b> RESPONSIVE ARCHITECTURE 1225 Eye Street NW Suite 210 Washington, DC 20005 Phone: (202) 244-4199 Fax: (202) 244-2997 www.moodynolan.com		SCHOOL OF ENGINEERING AND APPLIED SCIENCE LABORATORY RENOVATION UNIVERSITY OF DISTRICT OF COLUMBIA 4200 CONNECTICUT AVENUE, WASHINGTON, DC 20008 Fax: (###) ###-#### Phone: (###) ###-####		ISSUED WITH	SHEET REVISED
		SKETCH NUMBER <b>E112C</b>		PROJ #	DRAWN BY
		13334.01	AL	01/24/2014	

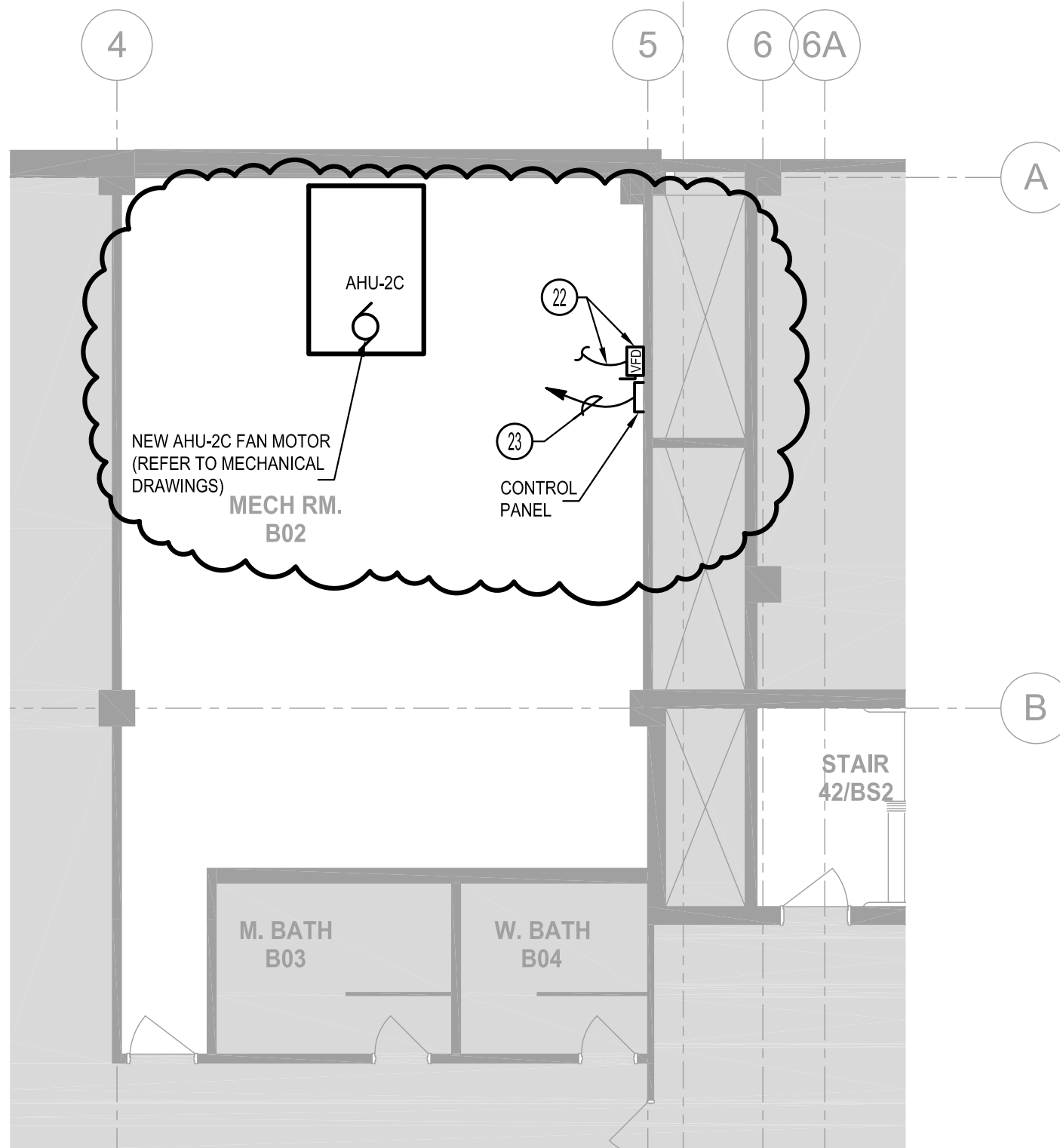

- NEW WORK KEY NOTES (PARTIAL):**
- 22 REPLACE MOTOR STARTER WITH NEW CONTROLLER VFD TYPE. FOR NEW 15HP FAN MOTOR. RECONNECT NEW VFD TO EXISTING BRANCH FEEDER. PROVIDE FINAL CONNECTION FROM VFD TO NEW AHU FAN MOTOR WITH 3#8+1#10AWG IN 3/4" LFMC.
  - 23 IDENTIFY AND CONNECT TO ONE SPARE CIRCUITS IN 120/208V PANEL IN ADJACENT ELECTRICAL ROOM WITH 2#12+1#12 (G) IN 3/4" CONDUIT. PROVIDE ONE NEW 20A/1 CIRCUIT BREAKERS.

**LEVEL B**  
**PART PLAN - POWER - NEW WORK**  
 SCALE: 1/8" = 1'-0"

<b>MOODY•NOLAN</b> RESPONSIVE ARCHITECTURE 1225 Eye Street NW Suite 210 Washington, DC 20005 Phone: (202) 244-4199 Fax: (202) 244-2997 www.moodynolan.com		SCHOOL OF ENGINEERING AND APPLIED SCIENCE LABORATORY RENOVATION UNIVERSITY OF DISTRICT OF COLUMBIA 4200 CONNECTICUT AVENUE, WASHINGTON, DC 20008 Fax: (###) ###-#### Phone: (###) ###-####		ISSUED WITH	SHEET REVISED
		PROJ # 13334.01		DRAWN BY AL	DATE 01/24/2014
				SKETCH NUMBER <b>E112D</b>	



TOTAL DEMAND=16-KVA(44AMPS)												TOTAL											
PANEL: 2LA-2(EXISTING)						NEUTRAL BUS: 100%						VOLTAGE: 208Y/120V 3Ø 4 WIRE + GND											
FED FROM: SEE POWER RISER						GROUND BUS: YES						MOUNTING: SURFACE						MAINS BUS: 100A, COPPER					
						ISOL. GND. BUS: NO						SSC RATING: 22 KAIC						MAIN PROT. DEVICE: 100A, MLO					
CIR. NO.	DESCRIPTION	FEEDER CONFIG.	KVA LOAD			BREAKER amps/poles	BREAKER amps/poles	KVA LOAD			FEEDER CONFIG.	DESCRIPTION	CIR. NO.	CIR. NO.									
			A	B	C			A	B	C													
1			2.5				20/1	0.7				EXISTING RECEPTACLES	2	1									
3	NEW PANEL 2LA2A ①	SEE POWER RISER		2.7		60/3	20/1		0.7			EXISTING RECEPTACLES	4	3									
5					2.5		20/1			0.7		EXISTING RECEPTACLES	6	5									
7	EXISTING RECEPTACLES		0.7			20/1	20/1	0.7				EXISTING RECEPTACLES	8	7									
9	EXISTING RECEPTACLES			0.7		20/1	20/1		0.7			EXISTING RECEPTACLES	10	9									
11	EXISTING RECEPTACLES				0.7	20/1	20/1			0.7		EXISTING RECEPTACLES	12	11									
13	EXISTING RECEPTACLES		0.7			20/1	20/1	0.7				EXISTING RECEPTACLES	14	13									
15	EXISTING RECEPTACLES			0.7		20/1	20/1		0.7			EXISTING RECEPTACLES	16	15									
17	EXISTING RECEPTACLES				0.7	20/1	20/1			0.7		EXISTING RECEPTACLES	18	17									
19	EXISTING RECEPTACLES		0.7			20/1	20/1	0.7				EXISTING RECEPTACLES	20	19									
21	EXISTING RECEPTACLES			0.7		20/1	20/1		0.7			EXISTING RECEPTACLES	22	21									
23	EXISTING RECEPTACLES				0.7	20/1	20/1			0.7		EXISTING RECEPTACLES	24	23									
25	EXISTING RECEPTACLES		0.7			20/1	20/1	0.7				EXISTING RECEPTACLES	26	25									
27	EXISTING RECEPTACLES			0.7		20/1	20/1		0.7			EXISTING RECEPTACLES	28	27									
29	EXISTING RECEPTACLES				0.7	20/1	20/1			0.7		EXISTING RECEPTACLES	30	29									
31	EXISTING RECEPTACLES		0.7			20/1	20/1	0.7				EXISTING RECEPTACLES	32	31									
33	EXISTING RECEPTACLES			0.7		20/1	20/1		0.7			EXISTING RECEPTACLES	34	33									
35	EXISTING RECEPTACLES				0.7	20/1	20/1			0.7		EXISTING RECEPTACLES	36	35									
37	EXISTING RECEPTACLES		0.7			20/1	20/1	0.7				EXISTING RECEPTACLES	38	37									
39	EXISTING RECEPTACLES			0.7		20/1	20/1		0.7			EXISTING RECEPTACLES	40	39									
41	EXISTING RECEPTACLES				0.7	20/1	20/1			0.7		EXISTING RECEPTACLES	42	41									
SUBTOTAL			6.7	6.9	6.7	EST. LOAD (KVA)			4.9	4.9	4.9	SUBTOTAL											
RECEPTACLES-- 27.3KVA(CONNECTED)						35.0KVA (CONNECTED)			11.6	11.8	11.6	TOTAL											
RECEPTACLES (DEMAND) = 10+0.5*(27.3-10) = 18.65KVA						14.1KVA (DEMAND)																	
MISCELLANEOUS = 7.7KVA																							
TOTAL DEMAND = 18.65+7.7=26.35KVA(DEMAND)																							
TOTAL DEMAND--26.35KVA(73AMPS)																							

**NEW WORK KEY NOTES:**

- ① REPLACE CIRCUIT BREAKERS 20A, 120V, 1-POLE WITH NEW CIRCUIT BREAKER 60A, 208V, 3-POLE. EXISTING CIRCUIT BREAKERS WILL BE AVAILABLE AFTER DEMOLITION OF RECEPTACLES IN LEVEL A CLASSROOM. SEE DRAWING E-111.

<b>MOODY•NOLAN</b> RESPONSIVE ARCHITECTURE 1225 Eye Street NW Suite 210 Washington, DC 20005 Phone: (202) 244-4199 Fax: (202) 244-2997 www.moodynolan.com		SCHOOL OF ENGINEERING AND APPLIED SCIENCE LABORATORY RENOVATION UNIVERSITY OF DISTRICT OF COLUMBIA 4200 CONNECTICUT AVENUE, WASHINGTON, DC 20008 Fax: (###) ###-#### Phone: (###) ###-####		ISSUED WITH	SHEET REVISED
		SKETCH NUMBER <b>E504A</b>		PROJ #	DRAWN BY
		13334.01	AL	01/24/2014	

TOTAL DEMAND=30KVA(83AMPS)

PANEL: 2L2-P(NEW)

FED FROM: SEE POWER RISER

NEUTRAL BUS: 100%

GROUND BUS: YES

ISOL. GND. BUS: NO

MOUNTING: SURFACE

SSC RATING: 22 KAIC

VOLTAGE: 208Y/120V 3Ø 4 WIRE + GND

MAINS BUS: 225A, COPPER

MAIN PROT. DEVICE: 150A, MCB

CIR. NO.	CIR. NO.	DESCRIPTION	FEEDER CONFIG.	KVA LOAD			BREAKER amps/poles	BREAKER amps/poles	KVA LOAD			FEEDER CONFIG.	DESCRIPTION	CIR. NO.
				A	B	C			A	B	C			
2	1	EXISTING RECEPTACLES	②	0.7			20/1	20/1	0.7			②	EXISTING RECEPTACLES	2
4	3	EXISTING RECEPTACLES	②		0.7		20/1	20/1		0.7		②	EXISTING RECEPTACLES	4
6	5	EXISTING RECEPTACLES	②			0.7	20/1	20/1			0.7	②	EXISTING RECEPTACLES	6
8	7	COMMUNICATION REC. LEVEL 2	2#10+1#10(G), 3/4"C	1.0			30/2	20/2	1.0			②	EXISTING	8
10	9				1.0					1.0				10
12	11	EXISTING RECEPTACLES	②			0.7	20/1	20/1			0.7	②	EXISTING RECEPTACLES	12
14	13	EXISTING RECEPTACLES	②	0.7			20/1	20/1	0.7			②	EXISTING RECEPTACLES	14
16	15	EXISTING RECEPTACLES	②		0.7		20/1	20/1		0.7		②	EXISTING RECEPTACLES	16
18	17	EXISTING RECEPTACLES	②			0.7	20/1	20/1			0.7	②	EXISTING RECEPTACLES	18
20	19	EXISTING RECEPTACLES	②	0.7			20/1	20/1	0.7			②	EXISTING RECEPTACLES	20
22	21	EXISTING RECEPTACLES	②		0.7		20/1	20/2		1.0		②	EXISTING	22
24	23	EXISTING RECEPTACLES	②			0.7	20/1				1.0	②	EXISTING	24
26	25	EXISTING RECEPTACLES	②	0.7			20/1		1.0			②	EXISTING	26
28	27	COMMUNICATION REC. LEVEL 2	2#10+1#10(G), 3/4"C		1.0		30/2	20/3		1.0		②	EXISTING	28
30	29					1.0				1.0				30
32	31			1.0				20/2	1.0			②	EXISTING	32
34	33	EXISTING	②		1.0		20/3			1.0		②	EXISTING	34
36	35					1.0		20/2			1.0	②	EXISTING	36
38	37	EXISTING	②	1.0			20/2		1.0			②	EXISTING	38
40	39				1.0			20/2		1.0		②	EXISTING	40
42	41	EXISTING RECEPTACLES	②			0.7	20/1				1.0	②	EXISTING	42

RECEPTACLES= 14.0KVA(CONNECTED) = 10+0.5\*(14-10)=12.0  
 MISCELLANEOUS = 22.0KVA  
 TOTAL DEMAND = 10+22=32KVA(DEMAND)  
 TOTAL DEMAND=32KVA(88AMPS)

SUBTOTAL 5.8 6.1 4.8  
 EST. LOAD (KVA)  
 35.3KVA (CONNECTED)  
 32.0KVA (DEMAND)

SUBTOTAL 6.1 6.4 6.1  
 TOTAL 11.9 12.5 10.9  
 PANELBOARD SHALL BE PROVIDED WITH MAIN CIRCUIT BREAKER, DOOR-IN-DOOR PANEL COVER AND COPPER BUSES.

**NEW WORK KEY NOTES:**

- ② EXISTING MAIN FEEDER AND BRANCH CIRCUITS TO BE RECONNECTED TO NEW PANEL 2L2-P. EXTEND EXISTING MAIN FEEDER AND BRANCH CIRCUITS AS REQUIRED. TRACE AND IDENTIFY EXISTING BRANCH CIRCUITS AND PROVIDE NEW UPDATED CARD DIRECTORY. COORDINATE WITH OWNER FOR CIRCUIT TRACING.

**MOODY•NOLAN**

RESPONSIVE ARCHITECTURE

1225 Eye Street NW Suite 210 Washington, DC 20005  
 Phone: (202) 244-4199 Fax: (202) 244-2997 www.moodynolan.com

SCHOOL OF ENGINEERING AND APPLIED SCIENCE LABORATORY RENOVATION

UNIVERSITY OF DISTRICT OF COLUMBIA

4200 CONNECTICUT AVENUE, WASHINGTON, DC 20008

Fax: (###) ###-#### Phone: (###) ###-####

ISSUED WITH SHEET REVISED

SKETCH NUMBER

**E504B**

PROJ # 13334.01 DRAWN BY AL DATE 01/24/2014